

品质改变世界
QUALITY CHANGES THE WORLD

SANY®

三一压路机

SANY ROLLERS



中国 湖南 长沙经济技术开发区三一工业城
Address: SANY Industry Town, Changsha National Economic & Technical Development Zone,
Hunan, China
邮编 Zip 410100
电话 Tel 0731-84031888 售后服务热线 After-sales service 4008 87 8318
传真 Fax 0731-84031999 咨询投诉电话 Consulting and complaint telephone 4008 87 9318

代理商信息
Agent Informatio

如产品配置（含技术参数）发生变动，恕不另行通知，以交机实物为准。
版权为三一重工所有，未经三一重工书面许可，本目录任何部分的内容不得被复制或抄袭用于任何目的。
三一重工市场部制作 2021年5月
As technology is being updated unceasingly, technical parameters are subject to change without prior notice. The machine in the picture may include auxiliary equipment. Copyright belongs to Sany Heavy Industry, no part of this catalogue can be reproduced or copied for any purpose without written permission of Sany Heavy Industry.
Produced by Sany Marketing Department May 2021.

www.sany.com.cn

SANY®



扫码得电子版



三一云二维码

www.sany.com.cn

目录 Contents



P05	三一路机 Sany Road Machinery
P07	三一 SSR 系列 单钢轮压路机 Sany SSR Series Single Drum Rollers
P19	三一 STR 系列 双钢轮压路机 Sany STR Series Tandem Drum Rollers
P21	三一 SPR 系列 轮胎压路机 Sany SPR Series Pneumatic Rollers
P31	精益制造 Lean Manufacturing
P33	品质保证 Quality Assurance
P35	施工案例 Construction Cases
P37	服务承诺 Service Commitment

三一路面机械

三一重工股份有限公司创建于1994年。自成立以来，公司以年均50%以上速度增长。目前已经发展为中国最大、全球前三的工程机械制造商，也是全球最大的混凝土机械制造商、国内最大最先进的成套道路施工设备供应商之一。

三一路面机械立足高端，是国内最大、最先进的成套道路施工设备供应商之一，主导产品涵盖摊铺机、压路机、平地机、铣刨机、沥青搅拌站五大系列产品，市场销售遍布欧美、非洲、东南亚、澳大利亚、俄罗斯等多个国家和地区。其中，全液压压路机、沥青站、摊铺机市场占有率居国内首位，摊铺机连续多年蝉联国内销量冠军。

近年来，三一路机更是开启数字化征程，成功研发全球首套无人驾驶摊铺压实机群，领先全球路机无人智能的发展，多次创下全球记录：全球“规模最大”的路机无人机群、全球首次“已营运”高速公路无人智能化机群施工、全球首次水稳面层无人智能化机群施工...三一无人驾驶机群正应用于不同工况的各大工程，并将引领中国公路建设快速迈向数字化施工新时代！



三一重工

SANY ROAD MACHINERY

SANY Industries Co., Ltd. was founded in 1994. When the company was established, it can be seen that the company has grown at an average annual rate of over 50%. Currently, China's largest and the world's top three construction machinery manufacturers are the world's largest concrete machinery manufacturers, which includes one of the largest and most advanced suppliers of complete sets of road construction equipment in China.

SANY Machinery has many features, which include being based on the high-end and being one of the largest and most advanced suppliers of complete sets of road construction equipment in China. Its leading products cover five series of products: pavers, rollers, graders, milling machines and asphalt mixing plants. In the market, sales are spread over many countries and regions such as Europe, America, Africa, Southeast Asia, Australia and Russia. The market share of hydraulic rollers, asphalt plants and pavers ranks first in China. Among them, pavers have been the domestic sales champion for many years in a row.

In recent years, SANY Machine is to open the digital journey, the world's first unmanned paving and compaction machine group was developed, the global road machine unmanned intelligent development, repeatedly set a global record can be led: the world's "largest" road machine unmanned fleet, the world's first "has operated The world's first "operational" unmanned intelligent fleet of highway machines. In the world, it is the first water-stable surface layer unmanned intelligent aircraft group construction... For SANY driverless fleet, which is being applied to major projects in different working conditions, is being led in the process of China's highway construction rapidly moving towards a new era of digital construction!

SANY SSR SERIES SINGLE DRUM ROLLER

三一 SSR 系列单钢轮压路机

更长的整机使用寿命

- ◆ 独创鼠袋式润滑装置充分润滑轴承，轴承使用寿命达 10000h 以上
- ◆ 发动机高位进气双重滤清，油路三级过滤

更强的施工适应性能

- ◆ 适用各类复杂的施工条件

更安全的人性化设计

- ◆ 集细致的人性化设计于一身，安全可靠

更高的压实作业效率

- ◆ 激振力在行业中比同类型号高出 10%，压实作业效率提升 16.7%

更舒适的灵动操控力

- ◆ 驾驶室减振效果达到良好级



LONGER SERVICE LIFE OF THE MACHINE

- ◆ The innovative squirrel-cage lubricating device can lubricate bearing fully making the service life of bearing longer than 10000 h.
- ◆ Engine is provided with high-level air inlet dual filters and oil circuit is provided with 3-level filtering.

VERSATILE COMPACTING CAPABILITY

- ◆ The exciting force is 10% higher than the products of similar type and model in the industry and compaction efficiency is 16.7% higher.

STRONGER CONSTRUCTION ADAPTATION CAPACITY

- ◆ Applicable to all kinds of complicated construction conditions

SAFER HUMANISTIC DESIGN

- ◆ Integrated with all humanistic design, safe and reliable

MORE COMFORTABLE AND FLEXIBLE OPERATING FORCE

- ◆ Good vibration reduction effect of cab

TECHNICAL PARAMETERS

技术参数

SSR 系列单钢轮压路机技术参数

SSR Series Single Drum Roller Technical Parameters

型号 Model		SSR200C-8H	SSR220C-8H	SSR220C-10	SSR200AC-8H	SSR220AC-8H	
质量载荷参数 Load	工作质量 (kg)	Operating mass (kg)	20000	22000	22000	20000	22000
	振动轮分配质量 (kg)	Distributing mass of vibratory drum (kg)	13600	14600	14600	10000	11000
	驱动桥分配质量 (kg)	Distributing mass of drive axle (kg)	6400	7400	7400	10000	11000
	振动轮静线载荷 (N/cm)	Static line load of vibratory drum (N/cm)	638	678	678	470	516
压实机构参数 Compaction	振动频率 (Hz)	Vibration frequency (Hz)	29/35	29/35	29/35	29/35	29/35
	名义振幅 (mm)	Nominal amplitude (mm)	2.0/1.0	2.0/1.0	2.0/1.0	1.9/0.95	1.9/0.95
	激振力 (kN)	Exciting force (kN)	380/275	390/280	390/280	368/258	390/280
	振动轮直径 (mm)	Dia. of vibratory drum (mm)	1600	1600	1600	1600	1600
	振动轮宽度 (mm)	Width of vibratory drum (mm)	2130	2130	2130	2130	2130
	振动轮轮圈厚度 (mm)	Thickness of drum (mm)	40	40	40	40	40
机动性能参数 Maneuverability	行驶速度	Traveling speed (km/h)	0 ~ 3.5 0 ~ 4.5	0 ~ 3.5 0 ~ 4.5	0 ~ 3.0 ~ 4.0 ~ 5.0 ~ 6	0 ~ 5	0 ~ 5
		0 ~ 5.5 0 ~ 7.5	0 ~ 5.5 0 ~ 7.5	0 ~ 3.0 ~ 4.0 ~ 5.0 ~ 8	0 ~ 8	0 ~ 8	
	理论爬坡能力	Theoretical gradeability (%)	45	45	50	30	30
	最小离地间隙 (mm)	Min. ground clearance (mm)	410	410	410	440	440
	轴距 (mm)	Wheelbase (mm)	3182	3182	3182	3185	3185
	转向角度 (°)	Steering angle (°)	±35	±35	±35	±35	±35
	摇摆角度 (°)	Swing angle (°)	±12	±12	±12	±12	±12
	最小转弯外直径 (mm)	Min. turning outside diameter (mm)	12350	12350	12350	12350	12350
轮胎规格	Tire spec.	23.1-26-8	23.1-26-8	23.1-26-12	20.5-25-16PR	20.5-25-16PR	
欧三发动机 Engine (Euro III)	供应商	Supplier	潍柴 WEICHAI	潍柴 WEICHAI	三一 SANY	潍柴 WEICHAI	潍柴 WEICHAI
	型号	Model	WP6G200E331	WP6G200E331	D05S3T7	WP6G200E331	WP6G200E331
	排放	Emissions	"国 III"	"国 III"	"国 III"	"国 III"	"国 III"
	额定功率 (kW)	Rated power (kW)	147	147	155	147	147
容量参数 Capacities	蓄电池, V×Ah	Storage battery (V×Ah)	24×120	24×120	24×120	24×120	24×120
	燃油箱 (L)	Fuel tank (L)	300	300	300	300	300
	液压油箱 (L)	Hydraulic oil tank (L)	150	150	150	100	100

主要尺寸 Main size	SSR200C-8H	SSR220C-8H	SSR220C-10	SSR200AC-8H	SSR220AC-8H	SSR260AC-8H	SSR260C-8	SSR330C-6	SSR360C-6
A (mm)	3182	3182	3182	3185	3185	3203	3471	3712	3678
W (mm)	2318	2318	2358	2270	2270	2380	2450	2590	2630
L (mm)	6620	6620	6697	6620	6620	6500	7060	7565	7497
D (mm)	1600	1600	1600	1600	1600	1700	1700	1800	1800
H (mm)	3330	3330	3190	3300	3300	3300	3330	3298	3298
B (mm)	2130	2130	2130	2130	2130	2170	2170	2250	2250
K (mm)	410	410	410	440	440	440	430	490	490

型号 Model		SSR260AC-8H	SSR260C-8	SSR330C-6	SSR360C-6	
质量载荷参数 Load	工作质量 (kg)	Operating mass (kg)	26000	26400	33500	36000
	振动轮分配质量 (kg)	Distributing mass of vibratory drum (kg)	13000	17400	22500	24000
	驱动桥分配质量 (kg)	Distributing mass of drive axle (kg)	13000	9000	11000	12000
	振动轮静线载荷 (N/cm)	Static line load of vibratory drum (N/cm)	610	788	1000	1067
压实机构参数 Compaction	振动频率 (Hz)	Vibration frequency (Hz)	27/32	28/32	28/31	28/31
	名义振幅 (mm)	Nominal amplitude (mm)	2.1/1.1	2.05/1.03	2.1/1.1	2.1/1.1
	激振力 (kN)	Exciting force (kN)	416/295	420/310	652/420	810/510
	振动轮直径 (mm)	Dia. of vibratory drum (mm)	1700	1700	1800	1800
	振动轮宽度 (mm)	Width of vibratory drum (mm)	2170	2170	2350	2350
	振动轮轮圈厚度 (mm)	Thickness of drum (mm)	40	40	50	50
机动性能参数 Maneuverability	行驶速度	Traveling speed (km/h)	0 ~ 5.5	0 ~ 4 0 ~ 6	0 ~ 5	0 ~ 5
		0 ~ 8	0 ~ 6.5 0 ~ 10	0 ~ 10	0 ~ 10	
	理论爬坡能力	Gradeability (%)	30	40/50	45/48	45/48
	最小离地间隙 (mm)	Min. clearance to ground (mm)	440	430	490	490
	轴距 (mm)	Wheelbase (mm)	3203	3471	3712	3678
	转向角度 (°)	Steering angle (°)	±35	±35	±35	±35
	摇摆角度 (°)	Swing angle (°)	±12	±12	±12	±12
	最小转弯外直径 (mm)	Min. turning outside diameter (mm)	12672	12800	13734	13700
轮胎规格	Tire spec.	23.5-25-16	23.5-25-16	23.5-25-16	23.5-25-16	
欧三发动机 Engine (Euro III)	供应商	Supplier	潍柴 WEICHAI	SANY	潍柴 WEICHAI	潍柴 WEICHAI
	型号	Model	WP6G200E331	D07S3-245E0	WP12G375E350	WP12G375E350
	排放	Emissions	"国 III"	"国 III"	"国 III"	"国 III"
	额定功率 (kW)	Rated power (kW)	147	180	276	276
容量参数 Capacities	蓄电池, V×Ah	Storage battery (V×Ah)	24×120	24×120	24×120	24×120
	燃油箱 (L)	Fuel tank (L)	300	300	400	400
	液压油箱 (L)	Hydraulic oil tank (L)	100	150	300	300

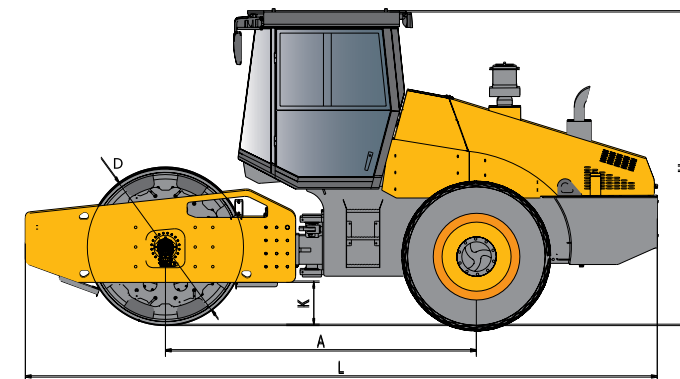
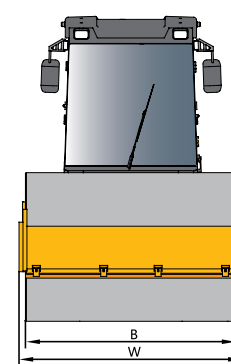

TECHNICAL PARAMETERS

技术参数

单钢轮压路机 SSR200C-8H/220C-8H/220C-10/200AC-8H/220AC-8H/260AC-8H 标配选配表

配置类型	配置名称	物料名称	总数量 / 台	详细说明	备注
标准配置	主机	SSR200C-8H 单钢轮压路机标配	1	1、发动机 2、行驶泵 3、振动泵 4、行驶马达 5、振动马达 6、减速机 7、驱动桥 8、驾驶室 9、振动轮 (光轮) 10、电气系统 11、操纵系统 12、前车架 13、后车架 14、覆盖件 15、后桥总成 16、中心铰接架 17、空调	\
		SSR220C-8H 单钢轮压路机标配	1		
		SSR220C-10 单钢轮压路机标配	1		
		SSR200AC-8H 单钢轮压路机标配	1		
		SSR220AC-8H 单钢轮压路机标配	1		
		SSR260AC-8H 单钢轮压路机标配	1		
可选配置	焊接式凸块振动轮	凸块振动轮	1	振动轮焊接凸块, 用于粘土、半粘土、岩石、碎石、膨胀土、煤渣等地基的压实, 而且凸块不能拆卸	可选配替代光轮
	装配式凸块振动轮	装配式凸块总成	1	振动轮装配凸块总成, 用于粘土、半粘土、岩石、碎石、膨胀土、煤渣等地基的压实, 拆卸凸块后, 可以作光轮压实, 实现一机两用。	加配

Single Drum Rollers SSR200C-8H/220C-8H/220C-10/200AC-8H/220AC-8H/260AC-8H Standard and Optional Configurations

Config	Name of Systems	Name of Parts	Quantity	Details	Remarks
Standard Configuration	Main Machine	SSR200C-8H Single Drum Roller, Standard	1	1.Engine 2.Travel Pump 3.Vibration Pump 4.Travel Motor 5.Vibration Motor 6.Reduction Gears 7.Drive axle 8.Cab 9.Vibratory Drum (Smooth) 10.Electrical System 11.Operating System 12.Front Frame 13.Rear Frame 14.Covering Part 15.Rear Axle Assembly 16.Center Articulated Frame 17. Air conditioner	\
		SSR220C-8H Single Drum Roller, Standard	1		
		SSR220C-10 Single Drum Roller, Standard	1		
		SSR200AC-8H Single Drum Roller, Standard	1		
		SSR220AC-8H Single Drum Roller, Standard	1		
		SSR260AC-8H Single Drum Roller, Standard	1		
Optional Configuration	Vibratory Drum with Welded Pad Foot	Drum with Welded Pad Foot	1	Vibratory drum with welded pad foot, which cannot be removed, suitable for compaction of clay, semi-clay, rocks, gravels, expansive soil, and coal cinder base	Substitute smooth drums permissible
	Vibratory Drum with Assembled Pad Foot	Drum with Assembled Pad Foot	1	Vibratory drum with assembled pad foot, which can be removed to form a smooth drum; suitable for compaction of clay, semi-clay, rocks, gravels, expansive soil, and coal cinder base	Optional

单钢轮压路机 SSR260C-8 标配选配表

配置类型	配置名称	物料名称	总数量 / 台	详细说明	备注
标准配置	主机	SSR260C-8 单钢轮压路机标配	1	1、发动机 2、行驶泵 3、振动泵 4、行驶马达 5、振动马达 6、减速机 7、驱动桥 8、驾驶室 9、振动轮 (光轮) 10、电气系统 11、操纵系统 12、前车架 13、后车架 14、覆盖件 15、后桥总成 16、中心铰接架 17、空调	必选
可选配置	装配式凸块振动轮	装配式凸块总成	1	振动轮装配凸块总成, 用于粘土、半粘土、岩石、碎石、膨胀土、煤渣等地基的压实, 拆卸凸块后, 可以作光轮压实, 实现一机两用。	加配

Single Drum Rollers SSR260C-8 Standard and Optional Configurations

Config	Name of Systems	Name of Parts	Quantity	Details	Remarks
Standard Configuration	Main Machine	SSR260C-8 Single Drum Roller, Standard	1	1.Engine 2.Travel Pump 3.Vibration Pump 4.Travel Motor 5.Vibration Motor 6.Reduction Gears 7.Drive axle 8.Cab 9.Vibratory Drum (Smooth) 10.Electrical System 11.Operating System 12.Front Frame 13.Rear Frame 14.Covering Part 15.Rear Axle Assembly 16.Center Articulated Frame 17.Air conditioner	Compulsory
Optional Configuration	Vibratory Drum with Assembled Pad Foot	Drum with Assembled Pad Foot	1	Vibratory drum with assembled pad foot, which can be removed to form a smooth drum; suitable for compaction of clay, semi-clay, rocks, gravels, expansive soil, and coal cinder base	Optional

TECHNICAL PARAMETERS

技术参数

单钢轮压路机 SSR330C-6/360C-6 标配选配表

配置类型	配置名称	物料名称	总数量 / 台	详细说明		备注
标准配置	主机	SSR330C-6 单钢轮压路机标配	1	1、发动机 2、行驶泵 3、振动泵 4、行驶马达 5、振动马达 6、减速机 7、驱动桥 8、驾驶室	9、振动轮(光轮) 10、电气系统 11、操纵系统 12、前车架 13、后车架 14、覆盖件 15、后桥总成 16、中心铰接架 17、空调	两种选一种
		SSR360C-6 单钢轮压路机标配	1			
可选配置	焊接式凸块振动轮	凸块振动轮	1	振动轮焊接凸块, 用于粘土、半粘土、岩石、碎石、膨胀土、煤渣等地基的压实, 而且凸块不能拆卸		可选配替代光轮
	装配式凸块振动轮	装配式凸块总成	1	振动轮装配凸块总成, 用于粘土、半粘土、岩石、碎石、膨胀土、煤渣等地基的压实, 拆卸凸块后, 可以作光轮压实, 实现一机两用。		加配

Single Drum Rollers SSR330C-6/360C-6 Standard and Optional Configurations

Config	Name of Systems	Name of Parts	Quantity	Details		Remarks
Standard Configuration	Main Machine	SSR330C-6 Single Drum Roller, Standard	1	1.Engine 2.Travel Pump 3.Vibration Pump 4.Travel Motor 5.Vibration Motor 6.Reduction Gears 7.Transaxle 8.Cab	9.Vibratory Drum (Smooth) 10.Electrical System 11.Operating System 12.Front Frame 13.Rear Frame 14.Covering Part 15.Rear Axle Assembly 16.Center Articulated Frame 17.Air conditioner	Select one out of two
		SSR360C-6 Single Drum Roller, Standard	1			
Optional Configuration	Vibratory Drum with Welded Pad Foot Shell Kit	Drum with Welded Pad Foot	1	Vibratory drum with welded pad foot, which cannot be removed, suitable for compaction of clay, semi-clay, rocks, gravels, expansive soil, and coal cinder base		This option can replace smooth drum
	Vibratory Drum with Removable Pad Foot Shell Kit	Drum with Assembled Pad Foot	1	Vibratory drum with assembled pad foot, which can be removed to form a smooth drum; suitable for compaction of clay, semi-clay, rocks, gravels, expansive soil, and coal cinder base		Optional

SANY STR SERIES TANDEM DRUM ROLLER

三一 STR 系列双钢轮压路机

安全舒适的人性化设计

- ◆ ROPS 认证驾驶室，可有效保证驾驶员的生命安全
- ◆ 驾驶室三级减振和空调确保舒适的工作环境，司机耳边噪声在 80dB 以内
- ◆ 驾驶室减振效果达到良好级
- ◆ 设计驻车旋钮、紧停按钮保证施工安全

SAFE AND COMFORTABLE HUMANISTIC DESIGN

- ◆ ROPS certification cab can safeguard driver more effectively
- ◆ 3-level vibration reduction and air conditioner of cab ensure a comfortable working environment; the noise that can be heard by driver is within 80 dB
- ◆ Good vibration reduction effect of cab
- ◆ Parking knob and emergency stop button are designed to ensure construction safety

ADVANCED VIBRATION WHEEL TECHNOLOGY

- ◆ The innovative squirrel-cage lubricating device can lubricate bearing fully, making the service life of bearing longer than 5,000 hr
- ◆ $\sigma \leq 0.6\text{mm}$ evenness, > 98% density, satisfying the rigid construction requirements of expressway pavement
- ◆ The height of side compaction clearance can be 825 mm

FLEXIBLE AND SMART OPERATION SYSTEM

- ◆ 90° right and left rotary control platforms facilitate compacting road edges
- ◆ The operating side box integrated with

vibration and driving handle is both convenient and flexible

RELIABLE SPRINKLER SYSTEM

- ◆ Water added in one time can be used for construction for longer than 5.7 hr
- ◆ It can avoid steel wheel from sticking to asphalt effectively
- ◆ Small spraying volume, slow temperature drop of asphalt and beneficial to compaction
- ◆ Standby spraying pump design ensures smooth construction
- ◆ Two rotational moulding water tanks accommodating 800 L

ADVANCED HYDRAULIC SYSTEM

- ◆ Closed hydraulic system brings high efficiency and reliability

ROBUST POWER SYSTEM

- ◆ Powerful and adaptive to all ramp construction conditions
- ◆ 3-level filtering of oil circuit
- ◆ Engine covers at both sides and accessible maintenance points

领先的振动轮技术

- ◆ 独创鼠袋式润滑装置充分润滑轴承，轴承使用寿命达 5000h 以上
- ◆ $\sigma \leq 0.6\text{mm}$ 高平整度、> 98% 高密实度，满足高速路面施工严苛要求
- ◆ 贴边压实接近间隙高度达到 825mm

灵动智能的操控系统

- ◆ 左右各 90° 旋转的操纵台，便于贴边压实
- ◆ 振动、行驶手柄一体化的操纵边箱，方便灵活

可靠的洒水系统

- ◆ 一次加水可正常施工 5.7h 以上
- ◆ 有效避免钢轮粘沥青
- ◆ 洒水量小，沥青温度下降慢，利于压实
- ◆ 备用的洒水泵设计，确保施工顺畅
- ◆ 共 800L 容积的两个滚塑水箱

先进液压系统

- ◆ 闭式液压系统，效率高，可靠性高

强劲的动力系统

- ◆ 动力强劲，适用坡道施工等各种工况
- ◆ 油路三级过滤
- ◆ 两侧开启发动机罩，各维修点触手可及



TECHNICAL PARAMETERS

技术参数

STR 系列全液压双钢轮压路机技术参数

型号		STR30C-8 (双驱前轮单振)	STR30C-8 (双驱双振)	型号		SZR30C-8 (组合)	STR 100C-8S	STR 100C-8C	STR 130C-8S	STR 130C-8C	STR 140C-8S	STR 140C-8C
质量 载 荷 参 数	工作质量 (kg)	3000	3000	工作质量 (kg)	2900	10500	10500	13000	13000	14000	14000	
	前轮分配质量 (kg)	1450	1450	前轮分配质量 (kg)	1400	5250	5250	6500	6500	7000	7000	
	后轮分配质量 (kg)	1550	1550	后轮分配质量 (kg)	1500	5250	5250	6500	6500	7000	7000	
	前轮静线载荷 (N/cm)	118	118	前轮静线载荷 (N/cm)	115	271	271	298	298	330	330	
钢 轮 尺 寸	后轮静线载荷 (N/cm)	126	126	后轮静线载荷 (N/cm)	490	271	271	298	298	330	330	
	振动轮直径 (mm)	700	700	振动频率 (Hz)	55/67	50/61; 40/50	50/61	50/61; 40/50	50/61	50/67; 40/55	50/67	
	振动轮宽度 (mm)	1200	1200	名义振幅 (mm)	0.5	0.75/0.3	0.75/0.3	0.67/0.31	0.67/0.31	0.62/0.28	0.62/0.28	
	振动轮轮廓厚度 (mm)	14	14	激振力 (kN)	46/28	140/94; 92/63	140/94	169/119; 110/80	169/119	169/143; 110/96	169/143	
振 动 参 数	振动频率 (Hz), 前轮	55/67	55/67	振动轮直径 (mm)	700	1240	1240	1300	1300	1400	1400	
	名义振幅 (mm), 前轮	0.5	0.5	振动轮宽度 (mm)	1200	1900	1900	2135	2135	2135	2135	
	激振力 (kN), 前轮	46/28	46/28	钢轮厚度 (mm)	14	17	17	20	20	20	20	
	振动频率 (Hz), 后轮	/	55/67	行驶 速度	高速 (km/h)	0-11	0-12	0-12	0-12	0-12	0-12	0-12
机 动 性 能 参 数	名义振幅 (mm), 后轮	/	0.5	速度	低速 (km/h)	0-6	0-6.5	0-6.5	0-6.5	0-6.5	0-6.5	
	激振力 (kN), 后轮	/	46/28	理论 爬坡 能力	振动 (%)	30	30	30	30	30	30	30
	行驶速度 (km/h)	0-11	0-11	爬坡 能力	不振 (%)	40	35	35	35	35	35	35
	理论爬坡能力振动 (%)	30	30	最小离地间隙 (mm)	233	360	360	380	380	490	490	
发 动 机	理论爬坡能力不振 (%)	40	40	轴距 (mm)	1700	3689	3689	3689	3689	3689	3689	
	最小离地间隙 (mm)	240	240	转向角度 (°)	±31	±33	±33	±33	±33	±33	±33	
	轴距 (mm)	1700	1700	摇摆角度 (°)	±6	±8	±8	±8	±8	±8	±8	
	转向角度 (°)	±30	±30	最小转弯外直径 (mm)	7050	13530	13530	14000	14000	15800	15800	
容 量 参 数	最小转弯外直径 (mm)	7050	7050	蟹行距离 (mm)	/	170	170	170	170	170	170	
	供应商	YANMAR	YANMAR	供应商	YANMAR	潍柴	康明斯	潍柴	康明斯	潍柴	康明斯	
	型号	3KNDA	3KNDA	型号	3KNDA	WP 4G154E331	QSB4.5	WP 4G154E331	QSB4.5	WP 4G154E331	QSB4.5	
	功率 (kW)	28.1	28.1	冷却系统	水冷	水冷	水冷	水冷	水冷	水冷	水冷	
容 量 参 数	蓄电池, V×Ah	12×40	12×40	排放	"国 III"	"国 III"	"国 III"	"国 III"	"国 III"	"国 III"	"国 III"	
	燃油箱 (L)	40	40	功率 (kW)	28.1	113	119	113	119	113	119	
	液压油箱 (L)	28	28	蓄电池 (V×Ah)	12×40	24×120	24×120	24×120	24×120	24×120	24×120	
				水箱 (L)	160	800	800	800	800	800	800	
			燃油箱 (L)	40	230	230	230	230	230	230		
			液压油箱 (L)	28	100	100	100	100	100	100		

Technical Parameter of STR Series Full Hydraulic Tandem Roller

Model		STR30C-8 (double drive, single vibration)	STR30C-8 (double drive, double vibration)	Model	SZR 30C-8 (combination)	STR 100C-8S	STR 100C-8C	STR 130C-8S	STR 130C-8C	STR 140C-8S	STR 140C-8C	
Load	Operating mass (kg)	3000	3000	Weight and Load	Operating Weight (kg)	2900	10500	10500	13000	13000	14000	14000
	Distributing mass of front wheel (kg)	1450	1450		Distributing mass of front wheel (kg)	1400	5250	5250	6500	6500	7000	7000
	Distributing mass of rear wheel (kg)	1550	1550		Distributing mass of rear wheel (kg)	1500	5250	5250	6500	6500	7000	7000
	Static line load of front wheel (N/cm)	118	118		Front wheel (N/cm)	115	271	271	298	298	330	330
Wheel	Static line load of rear wheel (N/cm)	126	126	Compaction Mechanism	Rear wheel (N/cm)	122	271	271	298	298	330	330
	Dia. of vibratory drum (mm)	700	700		Vibration Frequency (Hz)	55/67	50/61; 40/50	50/61	50/61; 40/50	50/61	50/67; 40/55	50/67
	Width of vibratory drum (mm)	1200	1200		Nominal amplitude (mm)	0.5	0.75/0.3	0.75/0.3	0.67/0.31	0.67/0.31	0.62/0.28	0.62/0.28
	Thickness of drum (mm)	14	14		Excitation Force (kN)	46/28	140/94; 92/63	140/94	169/119; 110/80	169/119	169/143; 110/96	169/143
Compaction	Vibration frequency (Hz)	55/67	55/67	Maneuverability	Drum Diameter (mm)	700	1240	1240	1300	1300	1400	1400
	Nominal amplitude (mm)	0.5	0.5		Drum Width (mm)	1200	1900	1900	2135	2135	2135	2135
	Exciting force (kN)	46/28	46/28		Drum Edge Thickness (mm)	14	17	17	20	20	20	20
	Nominal amplitude (mm)	0.5	0.5		Travel Speed	High (km/h)	0-11	0-11	0-11	0-12	0-12	0-12
Exciting force (kN)	/	55/67	Low (km/h)	0-6			0-6	0-6	0-6.5	0-6.5	0-6.5	0-6.5
Engine Capacities	Nominal amplitude (mm)	/		0.5		Theoretical Gradeability	Vibratory (%)	30	30	30	30	30
	Exciting force (kN)	/	46/28	Non-Vibratory (%)				40	35	35	35	35
	Travel speed (km/h)	0-11	0-11		Min. ground clearance (mm)		233	360	360	380	380	490
	Gradeability (vibrate) (%)	0-6	0-6	Wheelbase (mm)			1700	3689	3689	3689	3689	3689
Gradeability (not vibrate) (%)	30	30	Steering Angle (°)			±31	±33	±33	±33	±33	±33	±33
Min. clearance to ground (mm)	240	240				Swing Angle (°)	±6	±8	±8	±8	±8	±8
Wheelbase (mm)	1700	1700			Min Turning Outside Diameter (mm)		7800	13530	13530	14000	14000	15800
Steering angle (°)	±30	±30		Crab Distance (mm)			/	170	170	170	170	170
Swing angle (°)	±6	±6	Supplier				YANMAR	WEICHAI	Cummins	WEICHAI	Cummins	WEICHAI
Brand	YANMAR	YANMAR				Model	3KNDA	WP 4G154E331	QSB4.5	WP 4G154E331	QSB4.5	WP 4G154E331
Model	3KNDA	3KNDA			Cooling system		Water cooling	Water cooling	Water cooling	Water cooling	Water cooling	Water cooling
Emission	CN III	CN III		Emissions			CN III	CN III	CN III	CN III	CN III	CN III
Gross Output (kW)	28.1	28.1	Rated Power (kW)				28.1	113	119	113	119	113
Storage battery (V×Ah)	12×40	12×40				Storage battery (V×Ah)	12×40	24×120	24×120	24×120	24×120	24×120
Fuel tank (L)	40	40			Water Tank (L)		180	800	800	800	800	800
Hydraulic oil tank (L)	28	28		Fuel Tank (L)			40	230	230	230	230	230
Supplier	YANMAR	WEICHAI	Hydraulic Oil Tank (L)				28	100	100	100	100	100
Model	3KNDA	WP 4G154E331				Capacity	180	800	800	800	800	
Cooling system	Water cooling	Water cooling			40		230	230	230	230		
Emissions	CN III	CN III		28	100		100	100	100			
Rated Power (kW)	28.1	113	119	113	119		113	119				
Storage battery (V×Ah)	12×40	24×120	24×120	24×120	24×120	24×120	24×120					
Water Tank (L)	180	800	800	800	800	800						
Fuel Tank (L)	40	230	230	230	230	230						
Hydraulic Oil Tank (L)	28	100	100	100	100							

主要尺寸 Main size	SZR30C-8	STR30C-8	STR100C-8S	STR100C-8C	STR130C-8S	STR130C-8C	STR140C-8S	STR140C-8C
A (mm)	1700	1700	3689	3689	3689	3689	3689	3689
B (mm)	1200	1200	1900	1900	2135	2135	2135	2135
C (mm)	/	550	825	825	825	825	825	825
D (mm)	700	700	1240	1240	1300	1300	1400	1400
H (mm)	/	1755	2507	2507	2538	2538	2588	2588
H2 (mm)	2560	2560	3215	3215	3215	3215	3315	3315
K (mm)	233	240	360	360	380	380	490	490
L (mm)	2475	2550	5165	5165	5165	5165	5165	5165
W (mm)	1280	1280	2100	2100	2305	2305	2305	2305

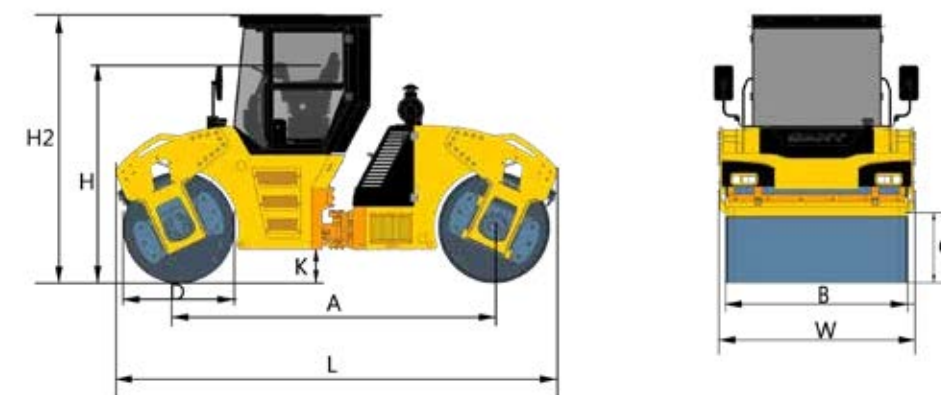

TECHNICAL PARAMETERS

技术参数

双钢轮压路机 SZR30C-8/STR30C-8 标配选配表

配置类型	配置名称	物料名称	总数量 / 台	详细说明		备注
标准配置	主机	SZR30C-8 双钢轮压路机标配	1	1. 发动机 2. 行驶泵 3. 振动泵 4. 行驶马达 5. 振动马达 6. 减速机 7. 操作平台 8. 中心铰接架	9. 电气系统 10. 振动轮 11. 前车架 12. 后车架 13. 洒水系统 14. 覆盖件 15. 空调	两种选一种
		STR30C-8 双钢轮压路机标配	1			

双钢轮压路机 STR100C-8S/100C-8C/130C-8S/130C-8C/140C-8S/140C-8C 标配选配表

配置类型	配置名称	物料名称	总数量 / 台	详细说明		备注
标准配置	主机	STR100C-8S STR100C-8C STR130C-8S STR130C-8C STR140C-8S STR140C-8C 双钢轮压路机标配	1	1. 发动机 2. 行驶泵 3. 振动泵 4. 行驶马达 5. 振动马达 6. 减速机 7. 驾驶室 + 空调 8. 中心铰接架	9. 电气系统 10. 振动轮 11. 旋转座椅 12. 前车架 13. 后车架 14. 洒水系统 15. 覆盖件	两种选一种
可选配置	驾驶室 + 空调	操作平台	1	上述驾驶室 + 空调改为操作平台		无驾驶室版本
	高原适应系统	高原适应系统	1	海拔 2500~4500 米高度施工		加配

Tandem Drum Rollers SZR30C-8/STR30C-8 Standard and Optional Configurations

Type	Name	Name of Parts	Quantity	Details		Remarks
Standard Configuration	Main Machine	SZR30C-8 Tandem Drum Roller, Standard	1	1.Engine 2.Travel Pump 3.Vibration Pump 4.Travel Motor 5.Vibration Motor 6.Reduction Gears 7.operating platform 8.Center Articulated Frame	9.Electrical System 10. Vibratory Drum 11.Front Frame 11.Rear Frame 13.Water-Spraying System 14. Covering Parts 15、 Air conditioner	Alternative
		STR30C-8Tandem Drum Roller, Standard	1			

Tandem Drum Rollers STR100C-8S/100C-8C/130C-8S/130C-8C/140C-8S/140C-8C Standard and Optional Configurations

Type	Name	Name of Parts	Quantity	Details		Remarks
Standard Configuration	Main Machine	STR100C-8S STR100C-8C STR130C-8S STR130C-8C STR140C-8S STR140C-8C Tandem Drum Roller, Standard	1	1.Engine 2.Travel Pump 3.Vibration Pump 4.Travel Motor 5.Vibration Motor 6.Reduction Gears 7. Cab+Air conditioner 8.Center Articulated Frame	9.Electrical System 10. Vibratory Drum 11. Rotating Seat 12.Front Frame 13.Rear Frame 14.Water-Spraying System 15. Covering Parts	Alternative
Optional Configuration	Cab+Air conditioner	Control console	1	The above cab + air conditioner is changed to operation platform		No cab
	High Altitude Adaptation System	High Altitude Adaptation System	1	Best for working at 2500 – 4500 altitude working conditions		Additional

SANY SPR SERIES PNEUMATIC TYRED ROLLER 三一 **SPR** 系列轮胎压路机



首创自动喷洒技术

- ◆ 油水混合，比例可调，省油省心
- ◆ 气辅助雾化，省去真空加油，简单高效
- ◆ 可省一个抹油工，大大节省客户成本
- ◆ 消除压路机行业人工抹油的安全隐患

集中自动充气系统

- ◆ 自动充气，气压可调
- ◆ 气压均匀一致，压实平整
- ◆ 即使轮胎漏气也可正常持续施工

全液压驱动系统

- ◆ 无级变速，起停平稳，减小了对路面的冲击
- ◆ 操作简单，上手快，劳动强度小

液压轮边制动技术

- ◆ 全液压制动可在发动机熄火、传动系统失效等极限状况下可靠制动6次，杜绝安全隐患
- ◆ 制动距离与行业平均距离相比短50%，彻底消除制动安全隐患
- ◆ 驱动桥常闭驻车制动，停机就制动，不需拉手刹

卓越的压实能力

- ◆ 满足沥青路面，水稳基层等各种压实需要

THE FIRST AUTOMATIC SPRAYING TECHNOLOGY

- ◆ The unique auto oil spraying technology prevents asphalt from sticking to tires, saving money and trouble free
- ◆ Pneumatic oil spraying, no oil pump required, guaranteeing stable work
- ◆ One oiling worker can be reduced to lower customer's costs
- ◆ It can also eliminate the safety hidden danger of artificial oiling in roller industry

FULL HYDRAULIC DRIVE SYSTEM

- ◆ Stepless speed change, stable start and stop and small pavement impact
- ◆ Simple operation, easy learning and small labor strength

EXCELLENT COMPACTION CAPACITY

- ◆ Diversified compaction demands such as asphalt pavement and water-stable macadam base can be satisfied.

CENTRALIZED AUTOMATIC INFLATION SYSTEM

- ◆ Automatic inflation and adjustable air pressure
- ◆ Even and consistent air pressure and even compaction
- ◆ Construction can be continued even if tyre leakage happens.

HYDRAULIC WHEEL SIDE BRAKE TECHNOLOGY

- ◆ The full hydraulic brake can brake for 6 times reliably in case of stalling of engine and transmission system failure to eradicate safety hidden danger
- ◆ The brake distance is 50% shorter than the average distance of the industry, eradicating safety hidden dangers thoroughly
- ◆ The normally closed parking brake of drive axle can brake as soon as the vehicle stops and hand brake is no longer needed

TECHNICAL PARAMETERS 技术参数

SPR 系列轮胎压路机技术参数

型号	SPR260C-8S	SPR300C-8S	
压实性能参数	最大工作质量 (kg)	26000	30000
	最小工作质量 (kg)	11000	11000
	接地比压 (kPa)	(200 ~ 520) / (200 ~ 420) *	(200 ~ 540) / (200 ~ 460) *
	单胎载荷 (吨)	2.88/2.36*	3.33/2.73*
	轮胎充气压力 (kPa)	200~800	200~800
	压实宽度 (mm)	2368/2740*	2368/2740*
	轮胎重叠量 (mm)	63/45*	63/45*
机动性能参数	工作速度 (km/h)	0~5.5/0~8	0~5.5/0~8
	行驶速度 (km/h)	0~10/0~14*	0~10/0~14*
	转向角度 (°)	30	30
	爬坡能力 (%)	25	25
	摇摆距离 (mm)	50	50
	离地间隙 (mm)	350	350
	轴距 (mm)	4170	4170
最小转弯外直径 (mm)	19000	19000	
发动机	供应商	潍柴	潍柴
	型号	WP6G190E301	WP6G190E301
	排放	NR3	NR3
	功率 (kW)	140	140
容量参数	蓄电池 (V × Ah)	24 × 120	24 × 120
	水箱 (L)	500	500
	燃油箱 (L)	200	200
	液压油箱 (L)	100	100

主要尺寸 Main size	SPR260C-8S	SPR300C-8S
L (mm)	5435	5435
B (mm)	2368/2740*	2368/2740*
H (mm)	3330	3330
A (mm)	4170	4170
W (mm)	2279/2579*	2279/2579*
K (mm)	350	350

注: * 代表前五后六
Note: * represents 5 front wheels and 6 rear axles

Technical Parameter of SPR Series Pneumatic Roller

Model	SPR260C-8S	SPR300C-8S	
Compaction	Max. Operating Weight (kg)	26000	30000
	Min. Operating Weight (kg)	11000	11000
	Ground Pressure (kPa)	(200 ~ 520) / (200 ~ 420) *	(200 ~ 540) / (200 ~ 460) *
	Single Tire Load (t)	2.88/2.36*	3.33/2.73*
	Tire Inflation Pressure (Kpa)	200~800	200~800
	Compaction Width (mm)	2368/2740*	2368/2740*
	Tire Overlapping (mm)	63/45*	63/45*
Maneuverability	Working Speed (km/h)	0~5.5/0~8	0~5.5/0~8
	Travel Speed (km/h)	0~10/0~14*	0~10/0~14*
	Steering Angle (°)	30	30
	Gradeability (%)	25	25
	Swing Distance (mm)	50	50
	Ground Clearance (mm)	350	350
	Wheelbase (mm)	4170	4170
Min. Turning Outside Diameter (mm)	19000	19000	
Engine	Supplier	WEICHAI	WEICHAI
	Model	WP6G190E301	WP6G190E301
	Emissions	NR3	NR3
	Power (kW)	140	140
Capacities	Storage battery (VxAh)	24 × 120	24 × 120
	Water Tank (L)	500	500
	Fuel Tank (L)	200	200
	Hydraulic oil tank(L)	100	100



TECHNICAL PARAMETERS

技术参数

轮胎压路机 SPR260C-8S/300C-8S 标配选配表

配置类型	配置名称	物料名称	总数量 / 台	详细说明	备注
标准配置	主机	SPR260C-8S 轮胎压路机标配	1	1、发动机 2、行驶泵 3、行驶马达 4、驾驶室 5、前覆盖件 6、前轮总成 7、后轮总成 8、电气系统 9、车架总成 10、喷洒系统 11、空调 12、集中充气 13、倒车可视	两种选一种
		SPR300C-8S 轮胎压路机标配	1		

Pneumatic Rollers SPR260C-8S/300C-8S Standard and Optional Configurations

Type	Name	Name of Parts	Quantity	Details	Remarks
Standard Configuration	Main Machine	SPR260C-8S Pneumatic Roller, Standard	1	1.Engine 2.Travel Pump 3.Travel Motor 4.Cab 5. Front Covering Part 6. Front Wheel Assembly 7. Rear Wheel Assembly 8. Electrical System 9. Frame Assembly 10. Spraying system 11.Air conditioner 12.Centralized inflation 13.Reversing visibility	Selecting one out of two
		SPR300C-8S Pneumatic Roller, Standard	1		

LEAN MANUFACTURING

精益制造

路机人挥洒汗水，精益求精
不断刷新中国制造的更高水平
更多的“第一”背后
是路机人改写中国制造至中国创造的实干之心

Personnel in the Company make every efforts to constantly strive for perfection and continuously achieve a higher Chinese manufacturing level;
Behind various reputable “No.1” achievements is their ambition to realize Chinese creation from Chinese manufacturing.



● 进口机床加工生产线
Imported Machining Production Line



● 进口卧式加工中心柔性线
Flexible line of imported horizontal machining center



● 专业的库存管理和防损措施
Professional Inventory Management and Damage Prevention Measures



● 无尘恒温的精密传动车间
Dust-free Constant Temperature Precision Transmission Workshop

精心设计、优化布局、技术革新、注重品控，实现路机产品全面流水化制造
生产管理信息化（MES 系统）、全自动焊接机器人、AGV 小车、自动化立体仓库……
不断开展自动化、智能化的创新研究，“新工艺、新设备、新材料”的广泛应用，极尽苛刻的质量品控，使得每一件路机产品至臻完美，面对各种复杂作业环境尽显卓越性能

三一人执着地闯出一条崭新的科技发展之路，为中国工程机械行业树立了全新的标杆
With meticulous design, optimal layout, technical innovation and emphasis on quality, the product can realize the full automatic manufacturing process of road machinery.
Production management information (MES system), full automatic welding robot, AGV trolley and automatic 3D warehouse...
With a strong focus on the innovation research of automation and intelligence constantly, the Company has applied "new technology, new equipment and new materials" widely and is always strictly on product quality to make all the road machine products perfect. The machines can show their superior performance under all different complicated operating environments.

All the staffs in Sany are brave to make scientific development, setting a typical example for Chinese engineering machinery industry.

QUALITY ASSURANCE

品质保证

研发试验体系

为打造一个国际领先的路面机械研发平台，三一路机依托工程机械远程监控服务与故障诊断实验室、液压实验室、机电液控与仿真实验室、柴油机实验室、设备疲劳（寿命）实验室、焊接实验室、强度（应力）实验室、耐磨材料实验室、汽车底盘全自动检测线等9大试验检测中心及58个企业级实验室，形成跨体系跨部门产品开发流程；

通过“试验基础设施、新产品开发试验、客户体验平台、工况模拟数据库”建设，建立了整车试验、零部件试验和仿真试验三级试验体系，目前已具备沥青站、摊铺机、平地机、压路机、铣刨机的开发及相关核心技术的研究、试验能力，全面提升研发核心竞争力。

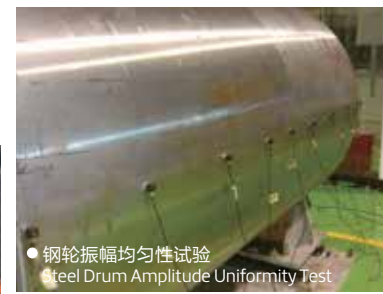
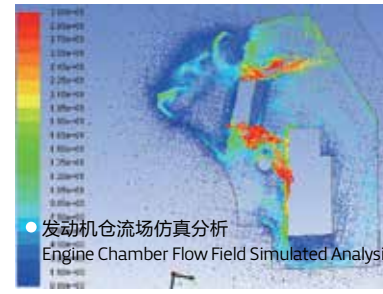

新产品开发试验 Testing for new product development



Construction Cases 施工案例



四川甘孜长河坝水电大坝工程

四川甘孜长河坝水电站堆石大坝工程，作业深度大，铺层厚度可达1米，最大粒径达0.9米，三一13台全液压单钢轮压路机参与建设。

Ganzichanghe Hydroelectric Dam Construction in Sichuan

13 units of single drum roller of SANY were used for the hydroelectric dam construction with high demand, layer thickness is up to 1 m, maximum diameter of stone is 0.9 m.



在糯扎渡水电大坝工程

云南省糯扎渡水电大坝工程目前亚洲最大，最高粘土芯墙堆石坝，坝高261.5米，长630米，坝底宽950米，坝顶宽13米，总体积2600万立方米。8台三一全液压单钢轮压路机参与建设。

Nuozhadu Hydroelectric Dam Construction in Yunnan

Nuozhadu Hydroelectric Dam Construction is currently Asia's largest and highest clay core rockfill dam, with height of 261.5 m, length of 630 m and width of 950m. The width of the top of dam is 13 m and the total volume is 26 million cubic meters. 8 Sany hydraulic single drum roller were used in its construction.

俄罗斯赤塔-哈巴的高速公路建设

俄罗斯赤塔-哈巴的高速公路长达2000公里，三一6台双钢轮压路机，3台轮胎压路机参与建设。

The Chita- Haba Expressway Construction in Russia

The Chita - Haba Highway Construction in Russia is 2000 kilometers long in total. 6 Sany tandem rollers and 3 pneumatic rollers were used in the construction.





三一路机 “123” 价值服务承诺

Road Machinery Product "123" Value Service Commitment



购买三一路机设备免费赠送人工服务费

◆ 路机产品按《操作保养手册》保养节点且使用三一纯正配件，免收人工服务费。



黑色路面产品关键部件保修期为 2 年或 2000 小时 (先到为准)

◆ 产品范围：摊铺机、双钢轮压路机、轮胎压路机、沥青搅拌站。



补偿一

◆ 产品质量问题引起停机故障 48 小时内未修复，优先提供备用机、无法提供备用机的按标准补偿；

补偿二

◆ 购买常用件 24 小时内未发货按标准补偿；

补偿三

◆ 压路机、平地机常用件高于市场价、按差价的 2 倍补偿。

以上条款的最终解释权归三一重工所有

售后服务热线
After-sale services
hotline **4008 87 8318**

咨询投诉电话
Consulting and
complaint telephone **4008 87 9318**

Clients who purchased SANY Road Machinery Equipments will be free of labor service fee

◆ Road machinery products shall be free of labor maintenance fee in accordance with the requirements of the Operation and Maintenance Manual for maintenance time nodes and using SANY certified accessories.

The warranty period for key parts of black Road Machinery Product is 2 years or 2,000 hours (whichever ends first)

◆ Product scope: Paver, Double Steel Roller, Tyre Roller, Asphalt Batching Plant.

Compensation I

◆ If the machine failure caused by product quality problems has not been repaired within 48 hours, clients should be provided the standby machine priority, and the situation where the standby machine cannot be used should be compensated according to the compensation standard.

Compensation II

◆ Clients will be compensated for non-delivery of common parts within 24 hours after purchase according to the compensation standard;

Compensation III

◆ If the price of common parts of Road Roller and Grader is higher than market price, clients will be compensated by 2 times the price difference.

The final interpretation of the above terms is owned by SANY Heavy Industry

久隆筑路机械保险 提供更贴心的服务

沥青搅拌站
财产保险

筑路机械
设备第三者
责任保险

雇主责任
保险

筑路机械
设备财产
一切保险



高性价比

价格更厚道，责任更宽泛

理赔快捷

领先行业水平，赔付更快捷

全面保障

产品创新，专业打造



基于装备制造业的专业财险公司