

品质改变世界
QUALITY CHANGES THE WORLD

SANY®



三一 C8 全系列铣刨机

SANY C8 WHOLE SERIES OF MILLING MACHINE



中国 湖南 长沙经济技术开发区三一工业城
Address SANY Industry Town, Changsha National Economic &
Technical Development Zone, Hunan, China
邮编 Zip 410100
电话 Tel 0731-84031888 售后服务热线 After-sales service 4008 87 8318
传真 Fax 0731-84031999 咨询投诉电话 Consulting and complaint telephone 4008 87 9318

代理商信息
Agent Information

如产品配置(含技术参数)发生变动,恕不另行通知,以交机实物为准。
版权为三一重工所有,未经三一重工书面许可,本目录任何部分的内容不得被复制或抄袭用于任何目的。
三一重工市场部制作 2021年5月
As technology is being updated unceasingly, technical parameters are subject to change without prior notice. The machine in the picture may include auxiliary equipment. Copyright belongs to Sany Heavy Industry, no part of this catalogue can be reproduced or copied for any purpose without written permission of Sany Heavy Industry.
Produced by Sany Marketing Department May 2021.

SANY®

www.sany.com.cn



扫码得电子版



三一云二维码

www.sany.com.cn

Best Milling Machine
Able to "Crack Hard Nuts"
最能啃“硬骨头”的铣刨机



P05	三一路机 SANY Road Machinery
P07	SCM500C-8H 铣刨机 SCM500C-8H Milling Machine
P11	SCM1000C-8/1300C-8 铣刨机 SCM1000C-8/1300C-8 Milling Machine
P15	SCM2000C-8 铣刨机 SCM2000C-8 Milling Machine
P19	精益制造 Lean Manufacturing
P21	品质保证 Quality Assurance
P23	施工案例 Construction Cases
P25	服务承诺 Service Commitment

三一路面机械

三一重工股份有限公司创建于 1994 年。自成立以来，公司以年均 50% 以上速度增长。目前已经发展为中国最大、全球前三的工程机械制造商，也是全球最大的混凝土机械制造商、国内最大最先进的成套道路施工设备供应商之一。

三一路面机械立足高端，是国内最大、最先进的成套道路施工设备供应商之一，主导产品涵盖摊铺机、压路机、平地机、铣刨机、沥青搅拌站五大系列产品，市场销售遍布欧美、非洲、东南亚、澳大利亚、俄罗斯等多个国家和地区。其中，全液压压路机、沥青站、摊铺机市场占有率居国内首位，摊铺机连续多年蝉联国内销量冠军。

近年来，三一路机更是开启数字化征程，成功研发全球首套无人驾驶摊铺压实机群，领先全球路机无人智能的发展，多次创下全球记录：全球“规模最大”的路机无人机群、全球首次“已营运”高速公路无人智能化机群施工、全球首次水稳面层无人智能化机群施工 ... 三一无人驾驶机群正应用于不同工况的各大工程，并将引领中国公路建设快速迈向数字化施工新时代！



三一重工

SANY ROAD MACHINERY

SANY Industries Co., Ltd. was founded in 1994. When the company was established, it can be seen that the company has grown at an average annual rate of over 50%. Currently, China's largest and the world's top three construction machinery manufacturers are the world's largest concrete machinery manufacturers, which includes one of the largest and most advanced suppliers of complete sets of road construction equipment in China.

SANY Machinery has many features, which include being based on the high-end and being one of the largest and most advanced suppliers of complete sets of road construction equipment in China. Its leading products cover five series of products: pavers, rollers, graders, milling machines and asphalt mixing plants. In the market, sales are spread over many countries and regions such as Europe, America, Africa, Southeast Asia, Australia and Russia. The market share of hydraulic rollers, asphalt plants and pavers ranks first in China. Among them, pavers have been the domestic sales champion for many years in a row.

In recent years, SANY Machine is to open the digital journey, the world's first unmanned paving and compaction machine group was developed, the global road machine unmanned intelligent development, repeatedly set a global record can be led: the world's "largest" road machine unmanned fleet, the world's first "has operated The world's first "operational" unmanned intelligent fleet of highway machines. In the world, it is the first water-stable surface layer unmanned intelligent aircraft group construction... For SANY driverless fleet, which is being applied to major projects in different working conditions, is being led in the process of China's highway construction rapidly moving towards a new era of digital construction!

SCM500C-8H MILLING MACHINE

SCM500C-8H 铣刨机

小巧灵活

- ◆ 整机高度 < 2.2m，能进地下车库铣刨。
- ◆ 铣刨半径 ≤ 0.325m，方便井盖、边角铣刨。

高效多能

- ◆ 功率大 (100kW)，小机身大能量，能铣刨改性沥青等硬路面。
- ◆ 铣刨鼓采用液压传动，动力传递更简单，配备铣刨鼓慢转功能，自动化程度高，换刀更省力。可搭配输料系统、变宽度刀具系统、降噪带方轮，满足不同施工需求。
- ◆ 670mm 大直径铣刨鼓，大通道、大容屑空间保证铣刨不堵料。
- ◆ 8km/h 行驶速度 + 33m/min 工作速度，转场、施工更高效。
- ◆ 标配四驱，强劲有力。



简单智能

- ◆ SYMC 智能控制器标配找平程序。
- ◆ 控制按钮通断、电流、电压均可可视化，易于检查、监测、维护。
- ◆ 智能提示维护保养信息、故障报警信息、铣刨方量统计等。
- ◆ 采用多功能集成手柄，操作舒适便捷。

EFFICIENT PLURIPOTENT

- ◆ High power (100kW), small fuselage, high energy, can mill modified asphalt and other hard pavement.
- ◆ Milling drum adopts hydraulic transmission, power transmission is more simple, equipped with milling drum slow rotation function, high degree of automation, more labor-saving tool change. It can be matched with material conveying system, variable width cutter system and boom belt square wheel to meet different construction requirements.
- ◆ 670 mm large diameter milling drum, large channel, large chip space, to ensure that milling without blocking material.
- ◆ 8km / h driving speed + 33m / min working speed makes the transition and construction more efficient.
- ◆ Standard 4WD, powerful.

COMPACT AND FLEXIBLE

- ◆ Machine height < 2.2m, can enter the underground garage milling planer
- ◆ Milling radius ≤ 0.325m, convenient hole cover edge and corner milling

EASY OPERATION & INTELLIGENT

- ◆ SYMC intelligent controller is equipped with leveling program as standard.
- ◆ The on-off, current and voltage of the control button are visualized, which is easy to check, monitor and maintain.
- ◆ Intelligent prompt maintenance information, fault alarm information, milling volume statistics, etc.
- ◆ It adopts multi-functional integrated handle, which is comfortable and convenient to operate.

TECHNICAL PARAMETER

技术参数

Technical Parameters of SCM500C-8H Milling Machine

SCM500C-8H 铣刨机技术参数

项目 Item		SCM500C-8H
发动机 Engine	厂家 / 型号 Manufacturer/model:	三一动力 D05/ 国Ⅲ
	额定功率 Rated power	100kW/2200rpm
	控制方式 Control mode	电子控制 Electronic control
	满负荷油耗 (L/h) Full load fuel consumption (L/h)	21
工作性能 Working performance	铣刨宽度 Milling width (mm)	500
	铣刨深度 Milling depth(mm)	0~180
	离地间隙 Ground clearance (mm)	250
	最大行驶速度 Maximum traveling speed (km/h)	8
铣刨鼓 Milling drum	刀间距 (mm) Cutter spacing (mm)	15
	刀具数 (个) Number of tools	50
	含刀具时转子直径 (mm) Rotor diameter with tool (mm)	670
重量 Weight	整机重量 (运输重量) Total weight(transported weight) kg	7t
	工作重量 Working weight(kg)	7.5t
行驶系统 Driving system	行驶档速度 (m/min) Driving speed (M/min)	0~133(0~8km/h)
	工作档速度 (m/min) Working gear speed (M/min)	0~33
	轮胎: 直径 × 宽度 (mm) Tire: diameter × width (mm)	Φ559×203
	支腿升降 Leg lifting	乌龟档 / 兔子档
箱体容量 Tank capacity	燃油箱 Fuel tank (L)	160
	液压油箱 Hydraulic oil tank (L)	80
	水箱 Water tank (L)	320
输料系统 Conveying system	皮带宽度 Belt width (mm)	400
	最大卸料高度 Max. conveying height (mm)	2900

备注:
工作重量包括半箱水、半箱燃油、机手 (75kg) 及刀具;
Note:
The working weight includes that of a half tank of water, a half tank of fuel, the operator (75 kg) and cutting tool.

主要尺寸 Main Dimension	SCM500C-8H
H1(mm)	3085
H2(mm)	2440
H3(mm)	2190
W1(mm)	950
W2(mm)	1380
W3(mm)	2085
L1(mm)	1800
L2(mm)	3370
L3(mm)	5990
L4(mm)	8640

Basic and Optional Configuration of SCM500C-8H Milling Machine

SCM500C-8H 铣刨机基本配置和选配方案

型号 Model	基本配置 Basic Configuration		选配 / 加配 Optional/Additional Configuration	
	基本配置 Basic Configuration	名称规格 Name and Specification	名称规格 Name and Specification	配置属性 Configuration Property
SCM500C-8H	三一动力发动机 + 四轮驱动 + 液压传动 + 标准刀间距铣刨鼓 + 机械式深度尺 SANYpower engine + 4WD + mechanical belt drive+ milling drum with the standard cutter space + standard leveling	/	可折叠输送机 Foldable conveyor	选配 Optional
			顶篷 Roof	选配 Optional
			0.35米铣刨刨鼓 0.35m milling drum	选配 Optional

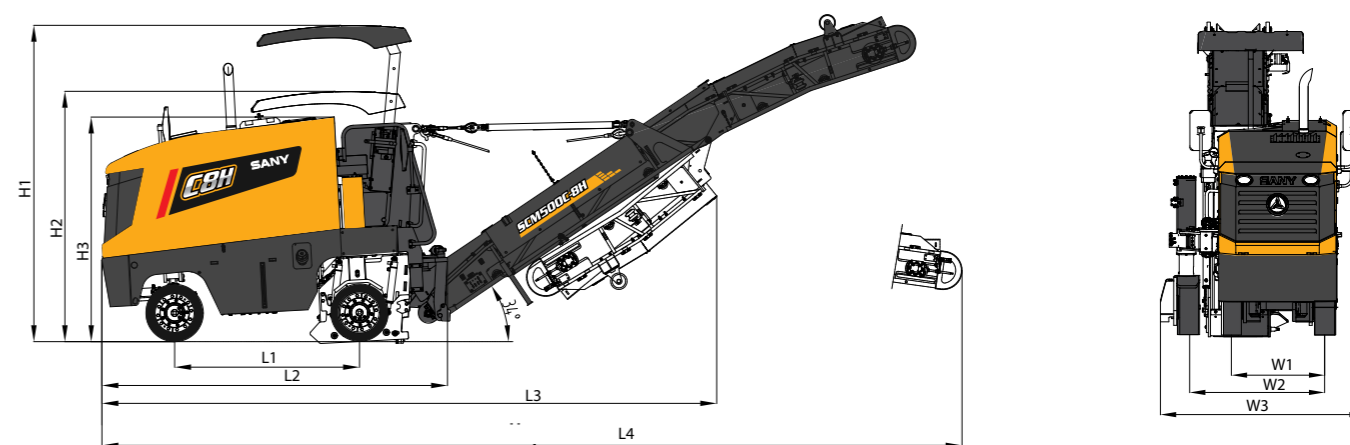

SCM1000C-8/1300C-8 MILLING MACHINE

SCM1000C-8/1300C-8 铣刨机

高效作业

- ◆ 180kw 发动机，动力充足。
- ◆ 铣刨采用机械传动，动力传递更直接，抗过载能力强。
- ◆ 标配四轮驱动，行驶强劲有力。
- ◆ 采用 500mm 超宽输送带，输料能力强。

适用性强

- ◆ 加宽的前轮轮距，轻松上下普通平板车。
- ◆ 铣刨半径 $\leq 1.2\text{m}$ ，方便边角铣刨。
- ◆ 行业最高的输送高度，能搭配“后八轮”协同作战。

方便智能

- ◆ 采用 SYMC 智能控制器，标配自动找平。
- ◆ 控制回路的通断、电流、电压等参数均可视，易于检查、监测和维护。
- ◆ 智能提示维护保养、故障报警等信息，铣刨量、位置等参数可查询。



经济可靠

- ◆ 15mm 标准间距铣刨鼓，铣刨纹理，摊铺更省料。
- ◆ 传动皮带采用松边张紧，皮带及张紧轴承寿命更长。
- ◆ 采用合金尾门刮刀，收料干净，寿命长。

HIGHLY EFFICIENT

- ◆ Type 180 kW engine maintains adequate power output
- ◆ Mechanical drive of milling ensures more direct power transmission and stronger resistance to overload.
- ◆ Standard four-wheel drive makes driving powerful.
- ◆ 500 mm ultra-wide conveyor ensures high material conveying capacity.

HIGHLY APPLICABLE

- ◆ Widened front wheel tread ensures easy access to ordinary flat car.
- ◆ Milling radius $\leq 1.2\text{ m}$ contributes to easy corner milling.
- ◆ The highest convey height in industry is able to be compatible with “dumper”.

CONVENIENT AND INTELLIGENT

- ◆ SYMC intelligent controller and standard Automatic Leveling System.
- ◆ Visible parameters of on/off, current and voltage for control circuit ensure easy inspection, monitoring and maintenance.
- ◆ Intelligent prompt of maintenance and fault alarm and searchable parameters such as milling level and position.

ECONOMICAL AND RELIABLE

- ◆ 15 mm standard pitch milling drum brings dense milling texture and saves materials.
- ◆ Drive conveyor has slack side and tensioning bearing to ensure a longer service life.
- ◆ Alloy tail gate scraper contributes to clean receiving of materials and a longer service life.

TECHNICAL PARAMETER

技术参数

Technical Parameters of SCM1000C-8/1300C-8 Milling Machine

SCM1000C-8/1300C-8 铣刨机技术参数

项目 Item		SCM1000C-8	SCM1300C-8	主要尺寸 Main Dimension	SCM1000C-8	SCM1300C-8
发动机 Engine	厂家 / 型号 Manufacturer/model:	三一动力 D07/ 国Ⅲ	三一动力 D07/ 国Ⅲ	H1(mm)	3480	3480
	额定功率 Rated power	180kW	180kW	H2(mm)	2690	2690
	控制方式 Control mode	电子控制 Electronic control	电子控制 Electronic control	H3(mm)	4500	4500
工作性能 Working performance	铣刨宽度 Milling width (mm):	1000	1300	W1(mm)	1450	1450
	铣刨深度 Milling depth(mm):	0~280	0~280	W2(mm)	1900	2200
	离地间隙 Ground clearance (mm)	280	280	W3(mm)	2320	2620
	最大行驶速度 Maximum traveling speed (km/h)	8	8	L1(mm)	2690	2690
重量 Weight	整机重量 (运输重量): Total weight (transported weight) kg:	14.5t	14.9t	L2(mm)	4890	4890
	工作重量 Working weight(kg):	15.2t	15.6t	L3(mm)	8550	8550
轮胎规格 Tyre specification	轮胎尺寸 Tyre size: 直径 × 宽度 (mm)	Φ620×255	Φ620×255	L4(mm)	12560	12560
箱体容量 Tank capacity	燃油箱 Fuel tank (L):	400	400			
	液压油箱 Hydraulic oil tank (L):	120	120			
	水箱 Water tank (L):	800	800			
输料系统 Conveying system	皮带宽度 Belt width (mm)	500	500			
	最大卸料高度 Max. conveying height (mm)	4500	4500			

备注:
工作重量包括半箱水、半箱燃油、机手 (75kg) 及刀具;

Note:
The working weight includes that of a half tank of water, a half tank of fuel, the operator (75 kg) and cutting tool.

Basic and Optional Configuration of SCM1000C-8/1300C-8 Milling Machine

SCM1000C-8/1300C-8 铣刨机基本配置和选配方案

型号 Model	基本配置 Basic Configuration		选配 / 加配 Optional/Additional Configuration	
	基本配置 Basic Configuration	名称规格 Name and Specification	名称规格 Name and Specification	配置属性 Configuration Property
SCM1000C-8/1300C-8	三一动力 D07 发动机 + 四轮驱动 + 机械皮带传动 + 标准刀间距铣刨鼓 + 自动找平 + 可折叠输料机 SANY D07 engine + 4WD + mechanical belt drive + milling drum with the standard cutter space + Automatic leveling + foldable conveyor	/	快换刀座铣刨鼓 (18mm 刀间距) Milling drum of quick change tool holder (18mm cutter spacing)	
		/	精铣刨鼓 (一线一齿) Fine milling drum (one milling tooth in a line)	加配 Additional
		/	精铣刨鼓 (一线二齿) Fine milling drum (two milling teeth in a line)	加配 Additional

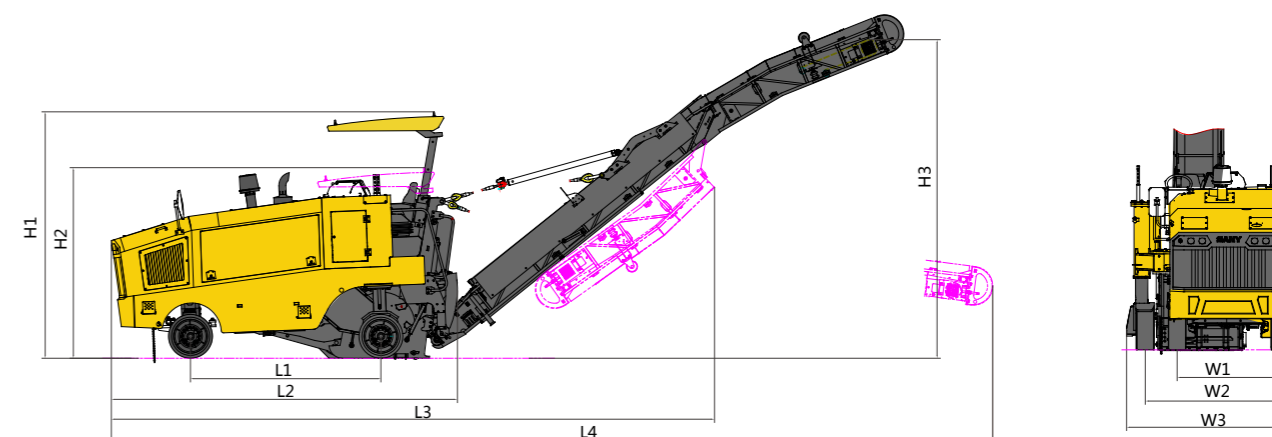

高效平稳

- ◆ 超大的铣刨鼓容屑空间，切削料排出快，铣刨速度更快。
- ◆ 最大 330mm 铣刨深度，可一次完成全厚度铣刨作业。
- ◆ 850mm 超宽输送带及更高的输送速度，保证超强输送能力。
- ◆ 重量及重心设计合理，作业更平稳。

适用性强

- ◆ 左右 60° 的摆角，适应各种复杂工况。
- ◆ 右侧滑板最大提升高度 450mm，贴边效果好。
- ◆ 美国康明斯 503KW 发动机，经济、高效、精细三档可选，满足不同需求。
- ◆ 可选配负压除尘系统，更好地满足环保要求。

SCM2000C-8S/2200C-8 MILLING MACHINE

SCM2000C-8S/2200C-8 铣刨机

轻松方便

- ◆ 快拆式设计，刀头拆卸更轻松。
- ◆ 旋转式坐姿操作，视野更好、工作强度更低。
- ◆ 可移动显示器，精简式操作面板及“一键施工”功能，操作更简单。
- ◆ 故障自诊断系统、超大维修空间，检修自查更方便。



EFFICIENT AND STABLE

- ◆ Extra-large debris space of milling drum brings fast drainage of cutting materials and fast milling.
- ◆ 330 mm maximum milling depth helps realize full-thickness milling at one time.
- ◆ 850 mm ultra-wide conveyor belt and higher transmission speed ensure ultra-strong transmission capacity.
- ◆ Reasonable weight and gravity center design makes operation stable.

HIGHLY APPLICABLE

- ◆ 60° swing angle on both sides makes it adaptive to all complex conditions.
- ◆ 450 mm maximum lifting height of right sliding plate brings good fitting.
- ◆ Economic, efficient and delicate 3-gear Commins

503 kW engine satisfies all operation demands.

◆ Optional negative pressure dedusting system better satisfies environmental protection.

CONVENIENT

- ◆ Fast disassembly tool contributes to easier removal.
- ◆ Rotary sitting operation brings better field of view and lower work intensity.
- ◆ Movable display, simple operation panel and “one-key construction” make operation easier.
- ◆ Fault self-diagnosis system and ultra-large maintenance room make self-inspection easier.

TECHNICAL PARAMETER

技术参数

Technical Parameters of SCM2000C-8S/2200C-8 Milling Machine

SCM2000C-8S/2200C-8 铣刨机技术参数

项 目		SCM2000C-8S	SCM2200C-8	主要尺寸 Main Dimension	SCM2000C-8S	SCM2200C-8
发动机 Engine	厂家 / 型号 Manufacturer/model	发动机 Engine QSX15 503kW Tier3 Cummins	发动机 Engine QSX15 503kW Tier3 Cummins	L1(mm)	15970	15970
	额定功率 Rated power	503kW@2100rpm	503kW@2100rpm	L2(mm)	15143	15143
	控制方式 Control mode	电子控制 Electronic control	电子控制 Electronic control	L3(mm)	12240	12240
工作性能 Working performance	铣刨宽度 Milling width(mm)	2010	2200	L4(mm)	8420	8420
	铣刨深度 Milling depth(mm)	0 ~ 330	0 ~ 330	H1(mm)	4700	4700
	行走速度 Travelling (milling) speed(m/min)	0 ~ 84(0 ~ 5km/h)	0 ~ 84(0 ~ 5km/h)	H2(mm)	3150	3150
	离地间隙 Ground clearance (mm)	310	310	H3(mm)	3091	3091
重量 Weight	整机重量 (运输重量) Total weight (transported weight)kg	31t	31.5t	X1(mm)	2160	2160
	工作重量 Working weight(kg)	33t	33.5t	X2(mm)	2660	2660
	最大工作重量: Max. working weight	35t	35.5t	W3(mm)	2660	2877
履带 Track (LxWxH,mm)	前履带 Front track (LxWxH/mm)	1852 x 320 x 670	1852 x 320 x 670	W2(mm)	2300	2300
	后履带 Rear track (LxWxH/mm)	1852 x 320 x 670	1852 x 320 x 670	H4(mm)	4064	4064
箱体容量 (L) Tank capacity	燃油箱 Fuel tank (L)	1080	1080	W1(mm)	1400	1400
	液压油箱 Hydraulic oil tank (L)	270	270			
	水箱 Water tank (L)	3200	3200			
材料输送系统 Material conveying system	一级皮带宽度 Level-1 belt width (mm)	850	850			
	二级皮带宽度 Level-2 belt width (mm)	850	850			
	最大输料高度 (mm) Max. conveying height(mm)	4700	4700			

备注:
1) 工作重量包括半箱水、半箱燃油、机手 (75kg) 及刀具;
2) 选配 2m 精铣刨鼓。
3) 铣刨宽度标配为 2010mm。

Note:
1) The working weight includes that of a half tank of water, a half tank of fuel, the operator (75 kg) and cutting tool;
2) Optional 2m fine milling drum
3) The standard milling width is 2,010 mm.

Basic and Optional Configuration of SCM2000C-8S/2200C-8 Milling Machine

SCM2000C-8S/2200C-8 铣刨机基本配置和选配方案

型号 Model	基本配置 Basic Configuration		选配 / 加配 Optional/Additional Configuration	
	基本配置 Basic Configuration	名称规格 Name and Specification	名称规格 Name and Specification	配置属性 Configuration Property
SCM2000C-8S	美国 Cummins 发动机 + SYMC 电控系统 + 标准间距铣刨鼓 + 两纵坡一横坡找平传感器 American Cummins engine + SYMC electronic control system + milling drum standard space + two longitudinal gradient leveling sensors and one cross gradient leveling sensor	2.0m 铣刨鼓 2.0m milling drum	2.0m 精铣刨鼓 (一线二齿) 2.0m fine milling drum (two teeth in a line)	选配 Optional
SCM2200C-8		2.2m 铣刨鼓 2.2m milling drum	2.2m 精铣刨鼓 (一线二齿) 2.2m fine milling drum (two teeth in a line)	选配 Optional

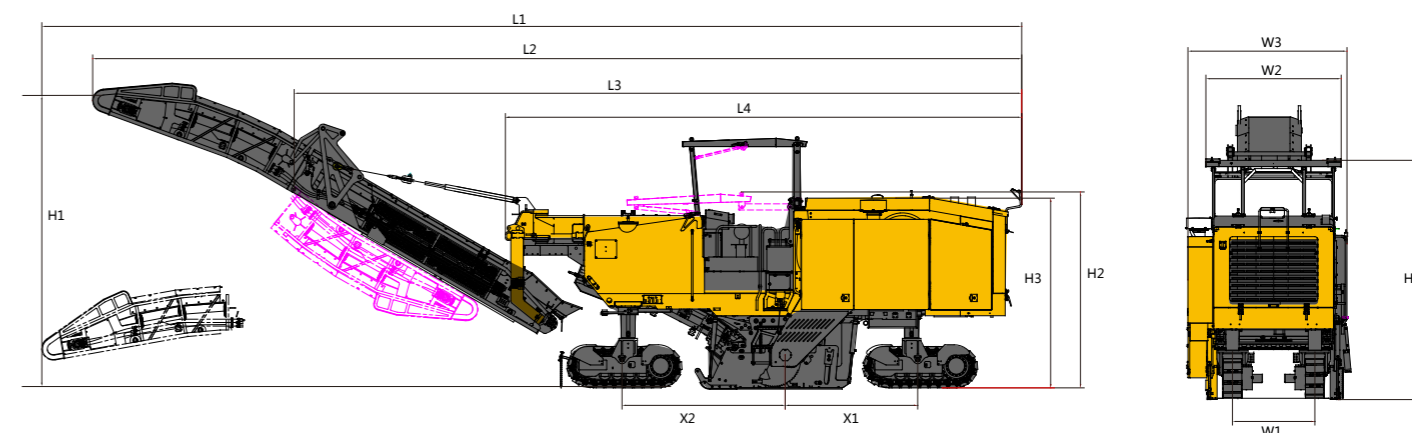

LEAN MANUFACTURING

精益制造

路机人挥洒汗水，精益求精
不断刷新中国制造的更高水平
更多的“第一”背后
是路机人改写中国制造至中国创造的实干之心

Personnel in the Company make every efforts to constantly strive for perfection and continuously achieve a higher Chinese manufacturing level;
Behind various reputable “No.1” achievements is their ambition to realize Chinese creation from Chinese manufacturing.



精心设计、优化布局、技术革新、注重品控，实现路机产品全面流水化制造
生产管理信息化（MES 系统）、全自动焊接机器人、AGV 小车、自动化立体仓库……
不断开展自动化、智能化的创新研究，“新工艺、新设备、新材料”的广泛应用，极尽苛刻的质量品控，使得每一件路机产品至臻完美，面对各种复杂作业环境尽显卓越性能

三一人执着地闯出一条崭新的科技发展之路，为中国工程机械行业树立了全新的标杆
With meticulous design, optimal layout, technical innovation and emphasis on quality, the product can realize the full automatic manufacturing process of road machinery.
Production management information (MES system), full automatic welding robot, AGV trolley and automatic 3D warehouse...
With a strong focus on the innovation research of automation and intelligence constantly, the Company has applied “new technology, new equipment and new materials” widely and is always strictly on product quality to make all the road machine products perfect. The machines can show their superior performance under all different complicated operating environments.

All the staffs in Sany are brave to make scientific development, setting a typical example for Chinese engineering machinery industry.

QUALITY ASSURANCE

品质保证

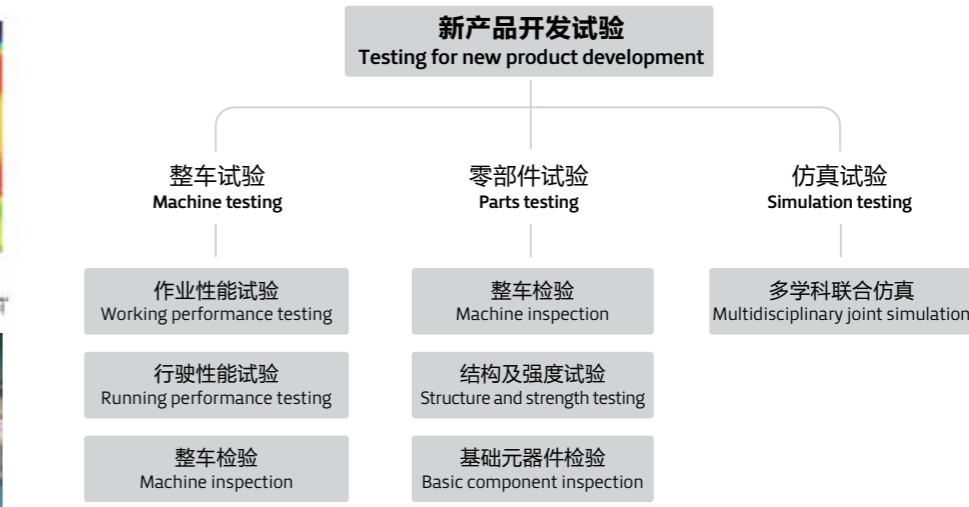

研发试验体系

为打造一个国际领先的路面机械研发平台，三一路机依托工程 机械远程监控服务与故障诊断实验室、液压实验室、机电液控与仿真实验室、柴油机实验室、设备疲劳（寿命）实验室、焊接实验室、强度（应力）实验室、耐磨材料实验室、汽车底盘全自动检测线等 9 大试验检测中心及 58 个企业级实验室，形成跨体系跨部门产品开发流程；

通过“试验基础设施、新产品开发试验、客户体验平台、工况 模拟数据库”建设，建立了整车试验、零部件试验和仿真试验 三级试验体系，目前已具备沥青站、摊铺机、平地机、压路机、铣刨机的开发及相关核心技术的研究、试验能力，全面提升研发核心竞争力。

R & D AND TEST SYSTEM

In order to create a world leading R & D platform for road machinery, Sany Road Machinery Co., Ltd. has formed a multi-system-and-department product development process in virtue of its 9 test and inspection centers such as remote monitoring service and fault diagnosis lab for engineering machinery, hydraulic lab, electromechanical hydraulic control and simulation lab, diesel lab, equipment fatigue (service life) lab, welding lab, strength (stress) lab, wearing resistant materials lab, auto chassis full automatic detection line and 58 enterprise labs.

By constructing "test infrastructure, new product development test, customer experience platform and working condition simulation database", Sany has established a 3-level system including whole vehicle test, parts test and simulation test; it has owned the development and relevant core technology research and test capacity of asphalt batching plant, paver, grader, road roller and milling machine.

CASES 施工案例



地点：山西省忻州市
时间：2019年7月
项目：五台山到忻州段道路返修
工况：施工长度2公里

Location: Shanxi Province, xinzhou
Time: July, 2019.
Project: Road Repair from Wutaishan to Xinzhou
Working Condition: Construction Length 2 km

地点：河南省驻马店泌阳县
时间：2017年12月
项目：砂石料采集
工况：330mm 铣刨

Location: Biyang County, Zhumadian City, Henan Province
Time: Dec. 2017
Project: Collection of sand aggregate.
Working Condition: 330mm milling



地点：云南玉溪
时间：2018年1月
项目：320国道施工
工况：5公分沥青铣刨

Location: Yuxi, Yunnan province
Time: Jan. 2018.
Project: Construction of 320# national road
Working Condition: Milling 5cm asphalt

地点：北京市
时间：2013年6月
项目：小区道路改造
工况：沥青铣刨50mm

Place: Beijing City
Time: June, 2013
Project: Road Reconstruction in a housing estate
Working duty: 50-mm asphalt pavement milling



地点：陕西
时间：2018年1月
项目：西汉高速施工
工况：3公分沥青铣刨

Location: Shanxi Province
Time: Jan. 2018.
Project: Construction of Xihan Highway
Working Condition: Milling 3cm asphalt

地点：河北省保定市徐水县
时间：2013年12月
项目：京港澳高速京石段拓宽工程
工况：沥青铣刨160-180mm

Place: Xushui County, Baoding City, Hebei Province
Time: December, 2013
Project: Broadening of Beijing-Shijiazhuang Section on G4 Highway
Working duty: 160~180-mm asphalt pavement milling





三一路机 “123” 价值服务承诺

Road Machinery Product "123" Value Service Commitment



购买三一路机设备免费赠送人工服务费

◆ 路机产品按《操作保养手册》保养节点且使用三一纯正配件，免收人工服务费。



黑色路面产品关键部件保修期为 2 年或 2000 小时 (先到为准)

◆ 产品范围：摊铺机、双钢轮压路机、轮胎压路机、沥青搅拌站。



补偿一

◆ 产品质量问题引起停机故障 48 小时内未修复，优先提供备用机、无法提供备用机的按标准补偿；

补偿二

◆ 购买常用件 24 小时内未发货按标准补偿；

补偿三

◆ 压路机、平地机常用件高于市场价、按差价的 2 倍补偿。

以上条款的最终解释权归三一重工所有

售后服务热线
After-sale services
hotline

4008 87 8318

咨询投诉电话
Consulting and
complaint telephone

4008 87 9318

Clients who purchased SANY Road Machinery Equipments will be free of labor service fee

◆ Road machinery products shall be free of labor maintenance fee in accordance with the requirements of the Operation and Maintenance Manual for maintenance time nodes and using SANY certified accessories.

The warranty period for key parts of black Road Machinery Product is 2 years or 2,000 hours (whichever ends first)

◆ Product scope: Paver, Double Steel Roller, Tyre Roller, Asphalt Batching Plant.

Compensation I

◆ If the machine failure caused by product quality problems has not been repaired within 48 hours, clients should be provided the standby machine priority, and the situation where the standby machine cannot be used should be compensated according to the compensation standard.

Compensation II

◆ Clients will be compensated for non-delivery of common parts within 24 hours after purchase according to the compensation standard;

Compensation III

◆ If the price of common parts of Road Roller and Grader is higher than market price, clients will be compensated by 2 times the price difference.

The final interpretation of the above terms is owned by SANY Heavy Industry



久隆筑路机械保险 提供更贴心的服务

沥青搅拌站
财产保险

筑路机械
设备第三者
责任保险

雇主责任
保险

筑路机械
设备财产
一切保险



高性价比

价格更厚道，责任更宽泛

理赔快捷

领先行业水平，赔付更快捷

全面保障

产品创新，专业打造



久隆保险
LONG Insurance

基于装备制造业的专业财险公司