

品质改变世界  
QUALITY CHANGES THE WORLD

SANY®

# 三一 C8 全系列摊铺机

SANY C8 WHOLE SERIES OF  
PAVERS



中国 湖南 长沙经济技术开发区三一工业城  
Address: SANY Industry Town, Changsha National Economic & Technical Development  
Zone, Hunan, China  
邮编 Zip 410100  
电话 Tel 0731-84031888 售后服务热线 After-sales service 4008 87 8318  
传真 Fax 0731-84031999 咨询投诉电话 Consulting and complaint telephone 4008 87 9318

代理商信息  
Agent Information

如产品配置(含技术参数)发生变动,恕不另行通知,以交机实物为准。  
版权为三一重工所有,未经三一重工书面许可,本目录任何部分的内容不得被复制或抄袭用于任何目的。  
三一重工市场部制作 2021年5月  
As technology is being updated unceasingly, technical parameters are subject to change without  
prior notice. The machine in the picture may include auxiliary equipment. Copyright belongs to Sany  
Heavy Industry, no part of this catalogue can be reproduced or copied for any purpose without written  
permission of Sany Heavy Industry.  
Produced by Sany Marketing Department May 2021.

www.sany.com.cn

SANY®



扫码得电子版



三一云二维码

www.sany.com.cn

**LEADING BRAND IN CHINA WITH  
WORLD CLASS QUALITY**

**国际品质 中国第一**

2011 年荣获中国“摊铺机第一品牌称号”  
连续 8 年，全国销量第一

Won "No. 1 Brand for Paver in China" in 2011.  
Sales ranked No. 1 in China for 8 consecutive  
years

P03	<b>三一路机</b> Sany Road Machinery
P05	<b>SSP 系列多功能摊铺机</b> SSP Series Multifunctional Paver
P11	<b>SAP 系列超级摊铺机</b> SAP Series Super Paver
P17	<b>精益制造</b> Lean Manufacturing
P19	<b>品质保证</b> Quality Assurance
P21	<b>施工案例</b> Construction Cases
P23	<b>服务承诺</b> Service Commitment



# 三一路面机械

三一重工股份有限公司创建于1994年。自成立以来，公司以年均50%以上速度增长。目前已经发展为中国最大、全球前三的工程机械制造商，也是全球最大的混凝土机械制造商、国内最大最先进的成套道路施工设备供应商之一。

三一路面机械立足高端，是国内最大、最先进的成套道路施工设备供应商之一，主导产品涵盖摊铺机、压路机、平地机、铣刨机、沥青搅拌站五大系列产品，市场销售遍布欧美、非洲、东南亚、澳大利亚、俄罗斯等多个国家和地区。其中，全液压压路机、沥青站、摊铺机市场占有率居国内首位，摊铺机连续多年蝉联国内销量冠军。

近年来，三一路机更是开启数字化征程，成功研发全球首套无人驾驶摊铺压实机群，领先全球路机无人智能的发展，多次创下全球记录：全球“规模最大”的路机无人机群、全球首次“已营运”高速公路无人智能化机群施工、全球首次水稳面层无人智能化机群施工...三一无人驾驶机群正应用于不同工况的各大工程，并将引领中国公路建设快速迈向数字化施工新时代！



三一重工

## SANY ROAD MACHINERY

SANY Industries Co., Ltd. was founded in 1994. When the company was established, it can be seen that the company has grown at an average annual rate of over 50%. Currently, China's largest and the world's top three construction machinery manufacturers are the world's largest concrete machinery manufacturers, which includes one of the largest and most advanced suppliers of complete sets of road construction equipment in China.

SANY Machinery has many features, which include being based on the high-end and being one of the largest and most advanced suppliers of complete sets of road construction equipment in China. Its leading products cover five series of products: pavers, rollers, graders, milling machines and asphalt mixing plants. In the market, sales are spread over many countries and regions such as Europe, America, Africa, Southeast Asia, Australia and Russia. The market share of hydraulic rollers, asphalt plants and pavers ranks first in China. Among them, pavers have been the domestic sales champion for many years in a row.

In recent years, SANY Machine is to open the digital journey, the world's first unmanned paving and compaction machine group was developed, the global road machine unmanned intelligent development, repeatedly set a global record can be led: the world's "largest" road machine unmanned fleet, the world's first "has operated The world's first "operational" unmanned intelligent fleet of highway machines. In the world, it is the first water-stable surface layer unmanned intelligent aircraft group construction... For SANY driverless fleet, which is being applied to major projects in different working conditions, is being led in the process of China's highway construction rapidly moving towards a new era of digital construction!

# SSP SERIES MULTIFUNCTIONAL PAVER SSP 系列多功能摊铺机

大厚度摊铺 唯我独尊

Heavy thickness pavement  
No.1 in China.



## 动力强劲

- ◆ 动力充分满足摊铺机各种工况下动力需求。
- ◆ 经济档转速下噪音更低，油耗更少，机器可靠性得到大幅提升。

## 经济

- ◆ 输料通道采用增厚耐磨钢板制作，耐磨件寿命提升 30%。
- ◆ 连续工作能力强，确保 50 度高温环境连续不停机作业要求。

## 高效

- ◆ 一次成型厚度达 50 厘米，可实现两层稳定土一次摊铺成型，提升工作效率 50%。
- ◆ 快速拼装熨平板，2 人可在 2.5 小时内完成 10 米熨平板拼装。
- ◆ 使用自主研发的 SYMC 控制系统，可实现远程技术支持和设备管理。
- ◆ 螺旋分料装置实现了一键整体提升，极大提高了设备的操作便捷性和工况适应能力。

### STRONG POWER

- ◆ The power can satisfy the paver's demands under different working conditions.
- ◆ Low noise, less oil consumption and better machine reliability under economic gear mode.

### EFFICIENCY

- ◆ It is able to ensure over 1,000 t/h paving capacity under all conditions, which is peerless in the industry.
- ◆ With 50cm paving thickness, it can realize the paving and molding of two layers of stable soils in one time, which can improve working efficiency by 50%.
- ◆ 2 persons can finish assembling 10 m screed within 2.5 hr.
- ◆ Adopt self-developed SYMC control system to achieve remote technical support and equipment management.
- ◆ The spiral feed divider can realize one-key overall lifting to improve equipment operation convenience and work adaptability significantly.

### ECONOMY

- ◆ The conveying channel is made of thickened wearing-resistant steel plate and the service life of wearing-resistant parts is increased by 30%.
- ◆ Strong continuous working capacity to ensure the non-stop working requirements under 50 °C temperature.

# TECHNICAL PARAMETER 技术参数

## SSP 系列多功能摊铺机技术参数

型号	SSP 系列多功能摊铺机			
	SSP185/165/145C-8	SSP125/130C-8	SSP90/100C-8	SSP80C-8
发动机型号	三一动力 D12S3T3	三一动力 D07S3	三一动力 D07S3	三一动力 D05S3
发动机额定功率 (kW)	320	180	180	155
发动机额定转速 (rpm)	2000	2200/2050	1600	2050
摊铺能力 (t/h)	1600	1000	900	800
最大摊铺厚度 (cm)	55	55	50	50
最大作业速度 (m/min)	16	16	16	23
最大转场速度 (km/h)	2.6	2.6	2.8	2.5
螺旋叶片 (mm)	(Φ480、Φ420、Φ360)/280	(Φ420、Φ360)/280	(Φ420、Φ360)/280	(Φ420、Φ360)/280
料斗容量 (m³)	8.5	8.5	8.5	8.5
熨平板选择	SSP185C-8	SA18530 (基本宽度 3m)		
	SSP165C-8	SA16530 (基本宽度 3m)		
	SSP145C-8	SA14530 (基本宽度 3m)		
	SSP130C-8	SA13030 (基本宽度 3m)		
	SSP125C-8	SF250 (基本宽度 2.5m)		
	SSP100C-8	SF250 (基本宽度 2.5m)		
	SSP90C-8	SE570 (基本宽度 3-5.7m, 机械加宽至 9.2m)		
	SSP80C-8	SE470 (基本宽度 2.5-4.7m, 机械加宽至 8.2m) 或 SE570 (基本宽度 3-5.7m, 机械加宽至 7.7m) SF250 (基本宽度 2.5m)		

## Technical Parameters of SSP Series Multifunctional Paver

Model	SSP Series Multifunctional Paver			
	SSP185/165/145C-8	SSP125/130C-8	SSP90/100C-8	SSP80C-8
Engine Model	SANY D12S3T3	SANY D07S3	SANY D07S3	SANY D05S3
Rated Power of Engine (Kw)	320	180	170	155
Rated Rotating Speed of Engine (rpm)	2000	2200/2050	2050	2050
Paving Capacity (t/h)	1600	1000	900	800
Max. Paving Thickness (cm)	55	55	50	50
Max. Paving Speed (m/min)	16	16	16	23
Max. Travel Speed (Km/h)	2.6	2.6	2.8	2.5
Auger blade (mm)	(Φ480、Φ420、Φ360)/280	(Φ420、Φ360)/280	(Φ420、Φ360)/280	(Φ420、Φ360)/280
Hopper Capacity (m³)	8.5	8.5	8.5	8.5
Options of Screed	SSP185C-8	SA18530 (basic width 3m)		
	SSP165C-8	SA16530 (basic width 3m)		
	SSP145C-8	SA14530 (basic width 3m)		
	SSP130C-8	SA13030 (basic width 3m)		
	SSP125C-8	SF250 (basic width 2.5m)		
	SSP100C-8	SF250 (basic width 2.5m)		
	SSP90C-8	SE570 (basic width 3-5.7m, Extensive width 9.2m: mechanical)		
	SSP80C-8	SE470 (basic width 2.5-4.7m, Extensive width 8.2m: mechanical) or SE570 (basic width 3-5.7m, Extensive width 7.7m: mechanical) SF250 (basic width 2.5m)		

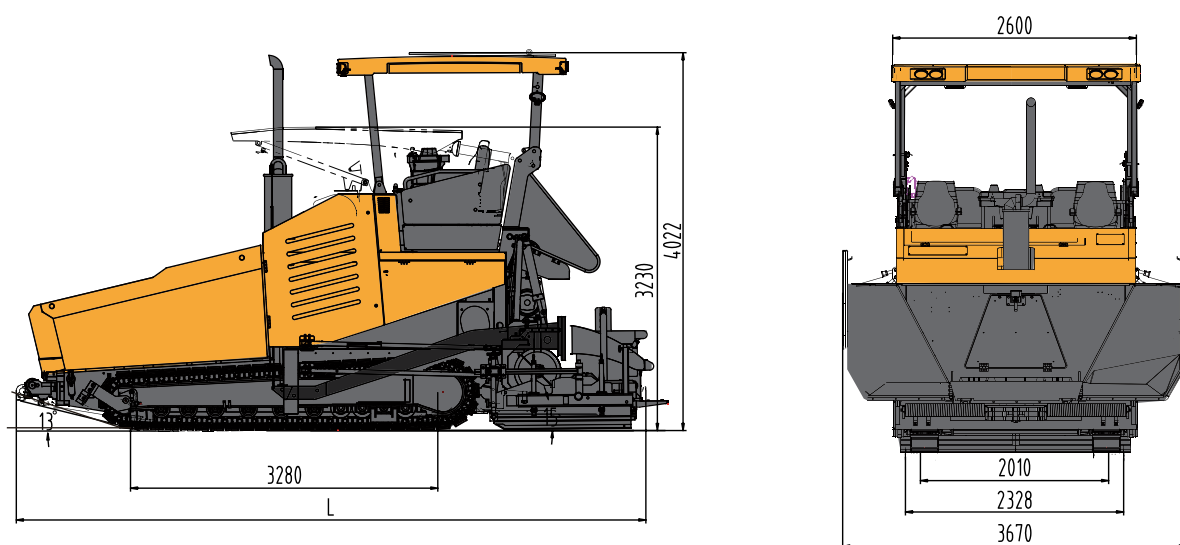

L 配 SF250 熨平板为 6710mm, 配 SE570/470 熨平板为 7250mm  
6710 mm screed equipped with SF250, and 7,250 mm screed equipped with SE570/470

# TECHNICAL PARAMETER 技术参数

SSP 系列多功能摊铺机基本配置及选配表

型号	所属部分	选项	标配	选配
	主机	找平仪	三一	MOBA
		其它	/	高原附件
SSP185C-8	SA18530	熨平板长度	18.5m	/
		加热方式	气加热	
		振动机构	有	
SSP165C-8	SA16530	熨平板长度	16.5m	/
		加热方式	气加热	
		振动机构	有	
SSP145C-8	SA14530	熨平板长度	14.5m	/
		加热方式	气加热	
		振动机构	有	
SSP130C-8	SA13030	熨平板长度	13m	/
		加热方式	气加热	
		振动机构	有	
SSP125C-8	SF250 拼装熨平板	熨平板长度	12.5m	10m
				9m
				8m
				6m
				2.5m
加热方式	气加热 (选配电加热)	/		
振动机构	有	/		
SSP100C-8	SF250 拼装熨平板	熨平板长度	10m	9m
				8m
				6m
				2.5m
				加热方式
振动机构	无	有		
SSP90C-8	SE570 伸缩熨平板	熨平板长度	9.2m	5.7m
				7.2m
				6.2m
				7.7m
加热方式	电加热 (选配边走边加热)	/		
振动机构	有	/		
SSP80C-8	SE470 伸缩熨平板	熨平板长度	8.2m	5.2m
				6.7m
				6.2m
				4.7m
	加热方式	电加热	/	
	振动机构	无	有	
	SF250 拼装熨平板	熨平板长度	8m	6m
				2.5m
				加热方式
	振动机构	无	有	
	SE570 伸缩熨平板	熨平板长度	7.7m	7.2m
5.7m				
7.7m				
加热方式				电加热
振动机构	无	有		

Basic and Optional Configuration of SSP Series Multifunctional Paver

Model	Part	Option	Standard Configuration	Optional
	Main machine	Levelling System	SANY (Control+Sensor)	MOBA
		Miscellaneous	/	High altitude accessories
SSP185C-8	SA18530	Screed length	18.5m	/
		Heating Mode	Gas Heated	
		Vibration Mechanism	Yes	
SSP165C-8	SA16530	Screed length	16.5m	/
		Heating Mode	Gas Heated	
		Vibration Mechanism	Yes	
SSP145C-8	SA14530	Screed length	14.5m	/
		Heating Mode	Gas Heated	
		Vibration Mechanism	Yes	
SSP130C-8	SA13030	Screed length	13m	/
		Heating Mode	Gas Heated	
		Vibration Mechanism	Yes	
SSP125C-8	SF250 splicing screed	Screed length	12.5m	10m
				9m
				8m
				6m
				2.5m
Heating Mode	Gas Heated ( Selection and distribution heating )	/		
Vibration Mechanism	Yes	/		
SSP100C-8	SF250 splicing screed	Screed length	10m	9m
				8m
				6m
				2.5m
				Heating Mode
Vibration Mechanism	NO	Yes		
SSP90C-8	SE570 expansion screed	Screed length	9.2m	5.7m
				7.2m
				6.2m
				7.7m
Heating Mode	Electric HeatedElectrical heating ( heating while traveling or operating-optional )	/		
Vibration Mechanism	Yes	/		
SSP80C-8	SE470 expansion screed	Screed length	8.2m	5.2m
				6.7m
				6.2m
				4.7m
	Heating Mode	Electric Heated	/	
	Vibration Mechanism	NO	YES	
	SF250 splicing screed	Screed length	8m	6m
				2.5m
				Heating Mode
	Vibration Mechanism	NO	Yes	
	SE570 expansion screed	Screed length	7.7m	7.2m
5.7m				
7.7m				
Heating Mode				Electric Heated
Vibration Mechanism	NO	Yes		

# SAP SERIES SUPER PAVER SAP 系列超级摊铺机

## 稳定可靠

- ◆ 电气汽车化线束——杜绝接线松动、接触不良，杜绝线路故障。
- ◆ 高效散热模型——机舱内部采用分舱导流技术，优化热量传递路线，提升散热能力，实现高温环境连续施工不停机。

## 领先技术带来摊铺效果好

- ◆ 高强熨平板——业内最强刚性设计，采用框架结构及双层防扭梁设计，施工更平整、更稳定。
- ◆ 输分料防离析技术——全比例输分料控制，匹配泵-马达模糊控制，大直径、大节距螺旋叶片提升搅拌均匀度，低匀速供料技术保证输料平稳性，提升路面平整度。
- ◆ 远程程序升级——提供最及时技术更新及服务。

## STABLE AND RELIABLE

- ◆ Electrical motorization hardness- eliminating loose wire and poor contact. Eliminating line faults.
- ◆ Highly efficient heat dissipation model-compartment heat division technique is used inside the compartment to optimize heat transfer line, improve heat dissipation capacity and ensure non-stop working under a high temperature environment.

## Advanced technique contributes to excellent paving effect

- ◆ Superior screed- the most rigid design in the industry; framework structure and dual-layer anti-beam torsion design are used to ensure more smooth and stable construction.
- ◆ Material conveying and distribution anti-separation technology-Full proportion material conveying and distribution control is matched with pump- motor fuzzy control; large diameter and pitch spiral impeller improves the mixing evenness; the low and constant speed supply technique satisfies the conveying stability and improves the pavement evenness.
- ◆ Remote program upgrading---providing timely technical upgrading and support.

# TECHNICAL PARAMETER

## 技术参数

### SAP 系列超级摊铺机技术参数

型号	SAP120C-8	SAP100C-8	SAP90C-8	SAP60C-8	SAP45TC-8	SAP45C-8	SAP30C-8
发动机型号	三一动力 D07S3	三一动力 D07S3	三一动力 D07S3	康明斯 QSB4.5	潍柴 WP4	潍柴 WP4	科勒 2504
发动机额定功率 (kW)	170	170	170	97	92	92	54.5
发动机额定转速 (rpm)	1900	2050	2050	2000	1900	1800	2200
摊铺能力 (t/h)	1100	900	900	450	250	320	250
最大摊铺厚度 (cm)	35	35	35	25	25	25	16
最大作业速度 (m/min)	24	16	16	20	25	20	30
最大转场速度 (km/h)	5.0	2.4	2.4	2.5	20	2.2	3.6
螺旋叶片 (mm)	( $\phi$ 480、 $\phi$ 400)/350	( $\phi$ 480、 $\phi$ 400)/350	( $\phi$ 480、 $\phi$ 400)/350	$\phi$ 360/280	$\phi$ 300/320	$\phi$ 300/320	$\phi$ 300
料斗容量 (m <sup>3</sup> )	8.5	8.5	8.5	6	6	6	2.7
熨平板选择	SF250	SF250	SE570	SE370	SE310/450	SE310/450	SE320

尺寸 Size	SAP120C-8	SAP100C-8	SAP90C-8	SAP60C-8	SAP45TC-8	SAP45C-8	SAP30C-8
A(mm)	3890	3890	3890	3760	3767	3710	1900
C(mm)	3278	3278	3278	2570	2787	2804	1576
D(°)	13	13	13	12	22	15	16.7
F(mm)	2700	2700	2700	2100	2056	1960	1400
G(mm)	2022	2022	2022	1505	1457	1302	986
H(mm)	3470	3470	3470	3265	3047	3210	3046
L(mm)	6790	6790	7250	6500	6618	6583	5294

### Technical Parameters of SAP Series Super Paver

Model	SAP120C-8	SAP100C-8	SAP90C-8	SAP60C-8	SAP45TC-8	SAP45C-8	SAP30C-8
Engine Model	SANY D07S3	SANY D07S3	SANY D07S3	CUMMINS QSB4.5	WEICHAI WP4	WEICHAI WP4	KOHLER2504
Rated Power of Engine (Kw)	170	170	170	97	92	92	54.5
Rated Rotating Speed of Engine (rpm)	1900	2050	2050	2000	1900	1800	2200
Paving Capacity (t/h)	1100	900	1100	450	250	320	250
Max. Paving Thickness (cm)	35	35	35	25	25	25	16
Max. Paving Speed (m/min)	24	16	24	20	25	20	30
Max. Travel Speed (Km/h)	5.0	2.4	2.4	2.5	20	2.2	3.6
Auger blade (mm)	( $\phi$ 480、 $\phi$ 400)/350	( $\phi$ 480、 $\phi$ 400)/350	( $\phi$ 480、 $\phi$ 400)/350	$\phi$ 360/280	$\phi$ 300/320	$\phi$ 300/320	$\phi$ 300
Hopper Capacity (m <sup>3</sup> )	8.5	8.5	8.5	6	6	6	2.7
Option of Screed	SF250	SF250	SE570	SE370	SE310/450	SE310/450	SE320

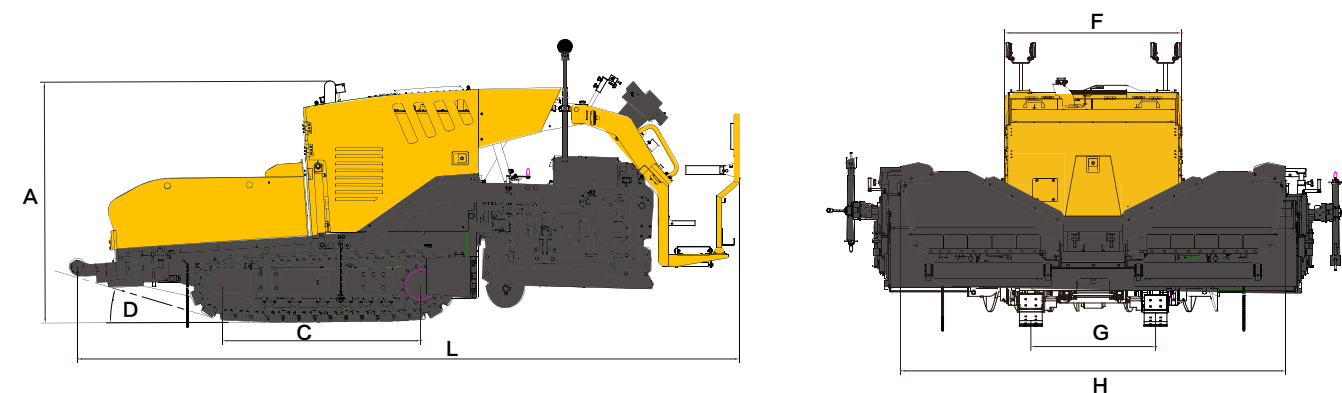
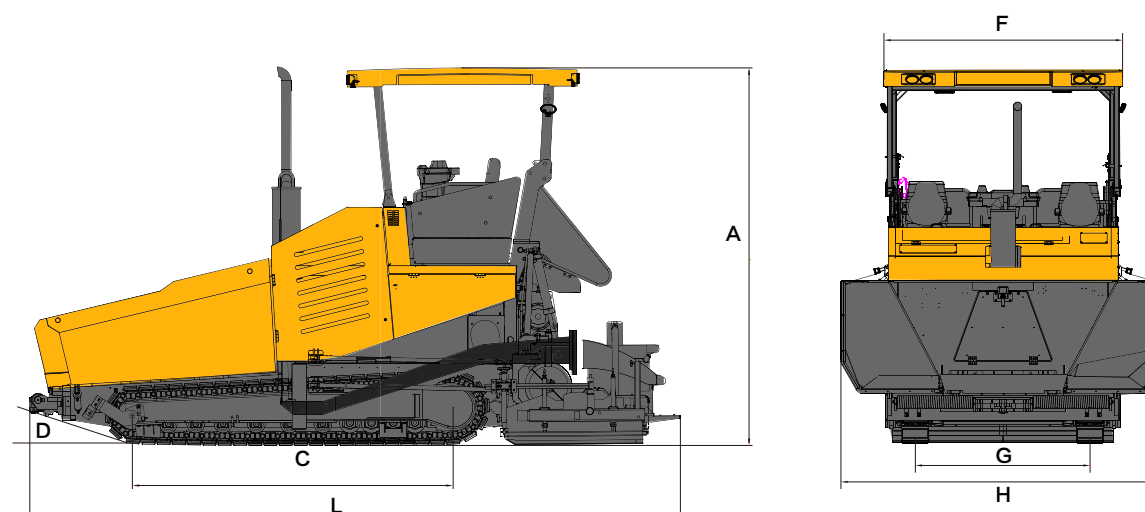

SAP30C-8 尺寸图



# TECHNICAL PARAMETER

## 技术参数

SAP 系列超级摊铺机基本配置及选配表

型号	所属部分	选项	标配	选配		
	主机	清洗装置	电动清洗	/		
		找平仪 + 平衡梁	SAP120C-8(MOBA)	三一		
		其它	/	高原附件		
SAP120C-8	SF250 拼装熨平板	熨平板长度	12m	11m		
				10m		
				9m		
				8m		
				6m		
				2.5m		
				加热方式	电加热	气加热
振动机构	有	/				
SAP100C-8	SF250 拼装熨平板	熨平板长度	10m	9m		
				8m		
				6m		
				2.5m		
				加热方式	电加热	气加热
振动机构	有	/				
SAP90C-8	SE570 伸缩熨平板	熨平板长度	9.2m	7.7m		
				7.2m		
				5.7m		
				加热方式	电加热	/
振动机构	有	/				
型号	所属部分	选项	标配	选配		
	主机	清洗装置	电动清洗	/		
		找平仪	三一	MOBA		
		其它	/	高原附件		
SAP60C-8	SE370 伸缩熨平板	熨平板长度	6m	5.2m		
				4.5m		
				2m		
				加热方式	电加热	气加热
振动机构	有	/				
SAP45C-8	SE310 伸缩熨平板	熨平板长度	4.5m	3.1/3.7m		
				加热方式	电加热	/
				振动机构	有	/
	SE450 伸缩熨平板	熨平板长度	4.5m	/	/	
					加热方式	电加热
振动机构	无	/				
SAP45TC-8	SE310 伸缩熨平板	熨平板长度	4.5m	3.1/3.7m		
				加热方式	电加热	/
				振动机构	有	/
	SE450 伸缩熨平板	熨平板长度	4.5m	/	/	
					加热方式	电加热
振动机构	无	/				
型号	所属部分	选项	标配	选配		
	主机	清洗装置	手动清洗	/		
		找平仪	三一	/		
		其它	/	/		
SAP30C-8	SE320EV 伸缩熨平板	熨平板长度	1.2-3.2m	/		
				/		
				加热方式	电加热	/
				振动机构	有	/

Basic and Optional Configuration of SAP Series Super Paver

Model	Part	Option	Standard Configuration	Optional		
	Main machine	Cleaning device	Electric	/		
		Leveling instrument+balance beam	SAP120C-8(MOBA)	SANY		
		Others	/	High altitude accessories		
SAP120C-8	SF250 splicing screed	Screed length	12m	11m		
				10m		
				9m		
				8m		
				6m		
				2.5m		
				Heating method	Electric heating	Gas heating
Vibration mechanism	Yes	/				
SAP100C-8	SF250 splicing screed	Screed length	10m	9m		
				8m		
				6m		
				2.5m		
Heating method	Electric heating	Gas heating				
Vibration mechanism	Yes	/				
SAP90C-8	SE570 expansion screed	Screed length	9.2m	7.7m		
				7.2m		
				5.7m		
Heating method	Electrical heating	/				
Vibration mechanism	Yes	/				
Model	Part	Option	Standard Configuration	Optional		
	Main machine	Cleaning device	Electric	/		
		Levelling system	SANY	MOBA		
		Others	/	High altitude accessories		
SAP60C-8	SE370 expansion screed	Screed length	6m	5.2m		
				4.5m		
				2m		
				Heating method	Electric heating	Gas heating
Vibration mechanism	YES	/				
SAP45C-8	SE310 expansion screed	Screed length	4.5m	3.1/3.7m		
				Heating method	Electric heating	/
				Vibration mechanism	YES	/
	SE450 expansion screed	Screed length	4.5m	/	/	
					Heating method	Electric heating
Vibration mechanism	NO	/				
SAP45TC-8	SE310 expansion screed	Screed length	4.5m	3.1/3.7m		
				Heating method	Electric heating	/
				Vibration mechanism	YES	/
	SE450 expansion screed	Screed length	4.5m	/	/	
					Heating method	Electric heating
Vibration mechanism	NO	/				
Model	Part	Option	Standard Configuration	Optional		
	Main machine	Cleaning device	Manual	/		
		Levelling system	SANY	/		
		Others	/	/		
SAP30C-8	SE320EV expansion screed	Screed length	1.2-3.2m	/		
				/		
				Heating method	Electric heating	/
				Vibration mechanism	YES	/

# LEAN MANUFACTURING

## 精益制造

路机人挥洒汗水，精益求精  
不断刷新中国制造的更高水平  
更多的“第一”背后  
是路机人改写中国制造至中国创造的实干之心

Personnel in the Company make every efforts to constantly strive for perfection and continuously achieve a higher Chinese manufacturing level;  
Behind various reputable “No.1” achievements is their ambition to realize Chinese creation from Chinese manufacturing.



● 进口机床加工生产线  
Imported Machining Production Line



● 进口卧式加工中心柔性线  
Flexible line of imported horizontal machining center



● 专业的库存管理和防损措施  
Professional Inventory Management and Damage Prevention Measures



● 无尘恒温的精密传动车间  
Dust-free Constant Temperature Precision Transmission Workshop

精心设计、优化布局、技术革新、注重品控，实现路机产品全面流水化制造  
生产管理信息化（MES 系统）、全自动焊接机器人、AGV 小车、自动化立体仓库……  
不断开展自动化、智能化的创新研究，“新工艺、新设备、新材料”的广泛应用，极尽苛刻的质量品控，使得每一件路机产品至臻完美，面对各种复杂作业环境尽显卓越性能

三一人执着地闯出一条崭新的科技发展之路，为中国工程机械行业树立了全新的标杆  
With meticulous design, optimal layout, technical innovation and emphasis on quality, the product can realize the full automatic manufacturing process of road machinery.  
Production management information (MES system), full automatic welding robot, AGV trolley and automatic 3D warehouse...  
With a strong focus on the innovation research of automation and intelligence constantly, the Company has applied “new technology, new equipment and new materials” widely and is always strictly on product quality to make all the road machine products perfect. The machines can show their superior performance under all different complicated operating environments.

All the staffs in Sany are brave to make scientific development, setting a typical example for Chinese engineering machinery industry.

# QUALITY ASSURANCE

## 品质保证

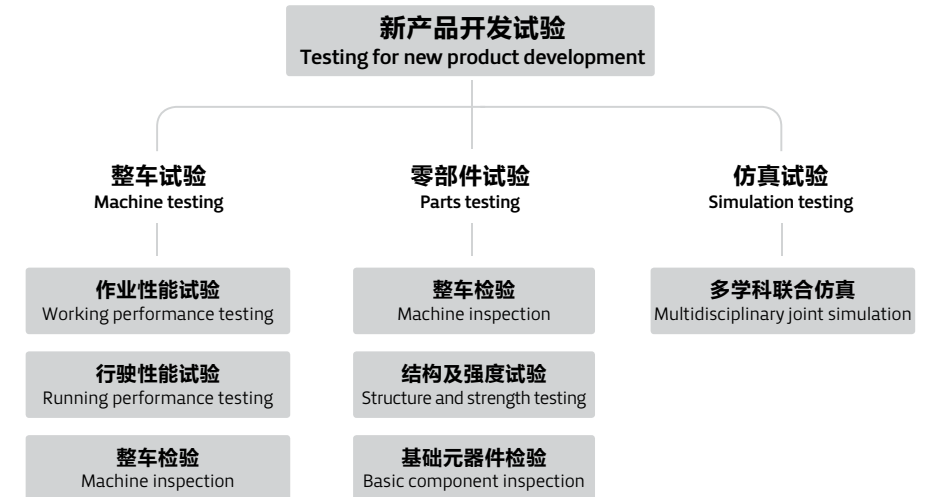

### 研发试验体系

为打造一个国际领先的路面机械研发平台，三一路机依托工程 机械远程监控服务与故障诊断实验室、液压实验室、机电液控与仿真实验室、柴油机实验室、设备疲劳（寿命）实验室、焊接实验室、强度（应力）实验室、耐磨材料实验室、汽车底盘全自动检测线等 9 大试验检测中心及 58 个企业级实验室，形成跨体系跨部门产品开发流程；

通过“试验基础设施、新产品开发试验、客户体验平台、工况 模拟数据库”建设，建立了整车试验、零部件试验和仿真试验 三级试验体系，目前已具备沥青站、摊铺机、平地机、压路机、铣刨机的开发及相关核心技术的研究、试验能力，全面提升研发核心竞争力。

### R&D and Test System

In order to create a world leading R & D platform for road machinery, Sany Road Machinery Co., Ltd. has formed a multi-system-and-department product development process in virtue of its 9 test and inspection centers such as remote monitoring service and fault diagnosis lab for engineering machinery, hydraulic lab, electromechanical hydraulic control and simulation lab, diesel lab, equipment fatigue (service life) lab, welding lab, strength (stress) lab, wearing resistant materials lab, auto chassis full automatic detection line and 58 enterprise labs.

By constructing “test infrastructure, new product development test, customer experience platform and working condition simulation database”, Sany has established a 3-level system including whole vehicle test, parts test and simulation test; it has owned the development and relevant core technology research and test capacity of asphalt batching plant, paver, grader, road roller and milling machine.

## CONSTRUCTION CASES 施工案例



### 湄潭高速公路建设

湄潭高速公路起于思南县黔鹤溪镇双龙村，经过铜仁地区思南县、德江县和遵义市凤冈县、湄潭县、遵义县、红花岗区止于遵义县龙坑镇，与杭瑞高速公路遵毕段相接，是贵州省高速公路网规划的重要组成部分。

施工设备：一台 SAP240C-5 高等级沥青摊铺机  
工程特点：该高速公路段长 20 公里，双向四车道，3 个月的施工时间，要对本公路进行中层和面层两层摊铺。

**CONSTRUCTION OF MEITAN EXPRESSWAY**  
By starting from Shuanglong Village, Yingwuxi Town, Sinan County, Sinan-Zunyi Expressway runs through Sinan County and Dejiang Town, Tongren District, and Fenggang Town, Meitan County, Zunyi County and Honghuagang District, Zunyi City and ends at Longkeng Town, Zunyi County. It connects Bijie Section, Hangzhou-Ruilu Expressway. It serves a critical part in Guizhou's expressway network planning.  
Construction equipment: One set of SAP240C-5 high-grade asphalt paver  
Construction features: This expressway is 20 km long with 4 lanes on each side. Construction period is 3 month. Middle layer and surface need to be paved.

### 遂资高速公路建设

遂资高速承建方在对比国内外众多筑路品牌，了解并查看施工现场和摊铺效果后，决定采用三一的高等级摊铺机 SAP240C-5 进行施工，打破了国内品牌上不了高速的“魔咒”。施工期间三一 SAP240C-5 凭借着优越的作业性能，高密实度，高平整度的摊铺效果，获得了各方的交口称赞。2012 年 8 月 3 日，路面研究院专业人员对摊铺路面进行检测，其摊铺的各项指标均达到高速路面专业标准。

**CONSTRUCTION OF SUINING-ZIYANG EXPRESSWAY**  
After comparing a number of foreign and domestic road building brands and understanding and investigating the construction site and paving effect, Suining-Ziyang Expressway contractor finally decided to use Sany high-grade paver SAP240C-5, which makes the history that domestic brand pavers cannot be used for expressway construction. During the construction period, Sany SAP240C-5 was praised highly by all parties thanks to its superior performance, and high density and high evenness paving effect. On August 3, 2012, the technicians from pavement research institute confirmed all pavement indexes reached the professional requirements for expressway pavement after detecting the pavement.



### 山东滕州城市道路施工

2017 年 7 月，山东滕州城市主干道施工，摊铺机 12 米宽，5cm 厚，摊铺速度 7.5m/min 左右，摊铺平整度高，表面质量高，得到客户和当地交通局领导的高度赞赏。

**CONSTRUCTION OF URBAN ROAD OF TENGZHOU, SHANDONG**  
The main urban road of Tengzhou, Shandong was constructed in July 2017. The paver is 12 m in width and 5 cm in thickness with the paving speed of about 7.5 m/min. The high paving evenness and surface quality won the praise of the client and local leaders from transportation bureau.



# 三一路机 “123” 价值服务承诺

Road Machinery Product "123" Value Service Commitment



## 1送 购买三一路机设备免费赠送人工服务费

◆ 路机产品按《操作保养手册》保养节点且使用三一纯正配件，免收人工服务费。



## 2保 黑色路面产品关键部件保修期为 2 年或 2000 小时 (先到为准)

◆ 产品范围：摊铺机、双钢轮压路机、轮胎压路机、沥青搅拌站。



## 3补 补偿一

◆ 产品质量问题引起停机故障 48 小时内未修复，优先提供备用机、无法提供备用机的按标准补偿；

## 补偿二

◆ 购买常用件 24 小时内未发货按标准补偿；

## 补偿三

◆ 压路机、平地机常用件高于市场价、按差价的 2 倍补偿。

以上条款的最终解释权归三一重工所有

售后服务热线  
After-sale services  
hotline

**4008 87 8318**

咨询投诉电话  
Consulting and  
complaint telephone

**4008 87 9318**

## Clients who purchased SANY Road Machinery Equipments will be free of labor service fee

◆ Road machinery products shall be free of labor maintenance fee in accordance with the requirements of the Operation and Maintenance Manual for maintenance time nodes and using SANY certified accessories.

## The warranty period for key parts of black Road Machinery Product is 2 years or 2,000 hours ( whichever ends first )

◆ Product scope: Paver, Double Steel Roller, Tyre Roller, Asphalt Batching Plant.

## Compensation I

◆ If the machine failure caused by product quality problems has not been repaired within 48 hours, clients should be provided the standby machine priority, and the situation where the standby machine cannot be used should be compensated according to the compensation standard.

## Compensation II

◆ Clients will be compensated for non-delivery of common parts within 24 hours after purchase according to the compensation standard;

## Compensation III

◆ If the price of common parts of Road Roller and Grader is higher than market price, clients will be compensated by 2 times the price difference.

The final interpretation of the above terms is owned by SANY Heavy Industry

# 久隆筑路机械保险 提供更贴心的服务

沥青搅拌站  
财产保险

筑路机械  
设备第三者  
责任保险

雇主责任  
保险

筑路机械  
设备财产  
一切保险



**高性价比**

价格更厚道，责任更宽泛

**理赔快捷**

领先行业水平，赔付更快捷

**全面保障**

产品创新，专业打造



基于装备制造业的专业财险公司