



90m



17.5m(可选两节9.5m延伸臂)



120m



5880kN·m



61t



STC2000C8-8(24款)

三一汽车起重机 SANY TRUCK CRANE

www.sanygroup.com

2024年1月版



QUALITY CHANGES THE WORLD

推介书内的参数、图片和配置仅供参考，实际配置以实物为准。

▶ 目录
Contents

Truck Crane

三一汽车起重机



01

Introduction

整机优势

▶ 04

02

Overall Dimensions

整车尺寸

▶ 06

03

Technical Specification

主要技术参数

▶ 07

04

Crane Introduction

整机配置

▶ 08

05

Counterweight Combinations

配重组合图

▶ 09

06

On-Site Heavy-Duty Driving Solutions

重载转场图

▶ 10

07

Working Range + Load Charts

起升高度曲线 + 起重性能表

▶ 11

主臂 (T)

主臂+副臂 (TJ)

主臂+延伸臂+副臂 (TEJ)

01 整机优势

Introduce

性能卓越 结构3.0平台

- 全面应用第3代混合型车架结构，车架截面面积增大9%，车架承重能力 \uparrow 15%，变形量 \downarrow 25%。
- 220T级超大截面主臂，响应面技术仿真优化分析，全伸臂挠度 \downarrow 10%，高频性能 \uparrow 8%。

操控领先 i-Hoisting 2.0系统

- 全新升级智能流量控制系统、双泵独立供油，操控精密、高速、平顺，助力吊装更精准。
- 回转工况自适应技术，依据整车吊载重量实时调节回转力矩，回转启停无晃动、冲击小，助力吊装更平稳。

稳行重器 重载转场1.0平台







- 配重结构重新优化，应用副配重自拆装技术，告别“小书包”、配重拆装无需辅吊。
- 重载转场技术，耐磨轮胎+高强度车桥+多轴平衡悬架，带载行驶能力 \uparrow 13%。

智能舒适 i-Crane智能起重机

- 工况推荐+自动伸缩的一键伸缩臂功能，依据最优工况快速伸缩臂、助力吊装便捷；
- 回转、伸缩、变幅以及卷扬操控动作实现参数自定义配置，提供3个档位响应满足不同工况操作需求，操作更为得心应手。



STC2000C8-8 (24款)
SANY TRUCK CRANE

-  90m
-  17.5m
(可选两节9.5m延伸臂)
-  120m
-  85km/h
-  6t
-  8.3(5.5) \times 7.7
-  154kW/2200rpm(东康)
338kW/1900rpm(潍柴)

-  分合流技术
-  回转工况自适应
-  自动伸缩
-  智能一键伸缩
-  多档位操控

02 整车尺寸

Overall Dimensions

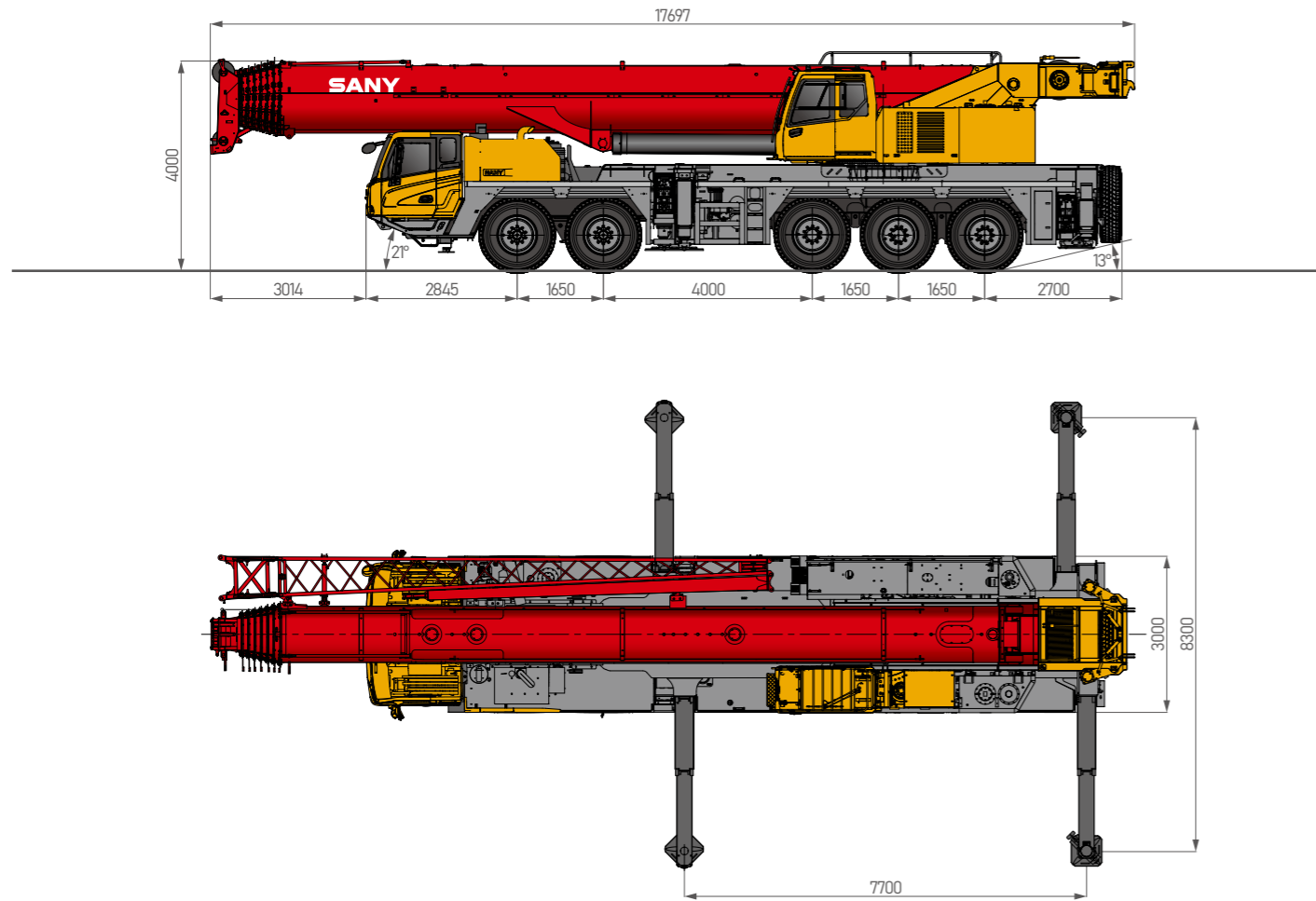

类型	项目	单位	参数	
尺寸参数	整机全长	mm	17697	
	整机全宽	mm	3000	
	整机全高	mm	4000	
重量参数 (常规公告状态)	整机总质量	kg	54990	
	载荷	一、二轴负荷	kg	19600
		三、四、五轴负荷	kg	35390
重量参数 (超限公告状态)	整机总质量	kg	60000	
	载荷	一、二轴负荷	kg	24000
		三、四、五轴负荷	kg	36000

注：
常规公告状态 - 拆6-8节臂，不带副臂、吊钩、配重，带备胎。
超限公告状态 - 拆4-8节臂，不带副臂、吊钩、配重，带备胎。

03 主要技术参数

Technical Specification

类型	项目	单位	参数	
上车动力参数	发动机型号	-	东康 QSB5.9CS4 220C	
	发动机最大功率	kW/rpm	154/2200	
	发动机最大输出扭矩	N-m/rpm	820/1600	
下车动力参数	发动机型号	-	潍柴WP12.460E62(国VI)	
	发动机最大功率	kW/rpm	338/1900	
	发动机最大输出扭矩	N-m/rpm	2200/1000~1400	
行驶参数	最高行驶速度	km/h	85	
	最小转弯半径	m	11.5	
	接近角 / 离去角	°	≥21/13	
	最大爬坡度	%	45%	
	百公里油耗	L	≤58(公告状态)	
主要性能参数	最大额定总起重量	T	200	
	转台尾部回转半径 (不带配重)	m	4.8	
	支腿跨距 (横向×纵向)	m	8.3(5.5)×7.7	
	起重臂长度	基本臂	m	15.1
		最长主起重臂	m	90
		最长主起重臂+副起重臂	m	101.5
		最长主起重臂+延伸臂 (选配)+副起重臂	m	120.5
	最大起重力矩	基本臂	kN-m	5880
		最长主起重臂	kN-m	2626
		最长主起重臂+副起重臂	kN-m	1172
最长主起重臂+延伸臂 (选配)+副起重臂		kN-m	789.9	











吊钩及倍率	额载 /t	滑轮数量	倍率	吊钩重量/kg
	9	0	1	310
	75	5	11	735

工作速度	项目	参数	钢丝绳直径 / 长度	最大单绳拉力
	主卷扬	单绳速度0~135m/min	20mm/375m	9t
回转		0~1.5r/min		
起幅 / 落幅		80s/100s(10~75°)		
伸臂 / 缩臂		800s/650s(15.1m~90m)		
垂直支腿伸出 / 缩回		40s/45s		
水平支腿伸出 / 缩回		25s/30s		











04 整机配置

Crane Introduction

上车/SupersTrucTure

	转台	▪ 三一自制结构件，高强度钢材制造，扭转刚度大、疲劳寿命长。
	操纵室	▪ 行业首创乘用车级舒适体验，配置全覆盖软化内饰、全景式天窗以及可调式座椅等人性化设计；配置10.1英寸显示屏，去实体按键设计，交互升级。
	液压系统	▪ 电控功率泵+电控主阀，排量实时调节、组合动作精准控制。
	发动机	▪ 东康柴油发动机，非道路国四，免加尿素。
	控制系统	▪ 采用集成一体式电气系统的总线仪表，实时监控行驶参数与作业参数。
	起升机构	▪ 常闭式卷扬减速机、轴向柱塞马达并采用防溜钩技术。
	变幅系统	▪ 创新落幅自动补偿技术，落幅工况更快更稳。
	回转系统	▪ 1900mm直径加强型回转支撑、双减速机配置、电比例回转缓冲系统，回转平稳无冲击。
	安全装置	▪ 液压溢流阀、平衡阀、双向液压锁、力矩限制器、三圈保护器、高度限位器和卷扬监视装置。
	伸缩臂架	▪ 8节单缸插销主臂，由高强度焊接结构钢制成，卵圆形截面，副臂17.5m、可选配两节9.5m延伸臂。
	配重	▪ 标配6T配重，可后移1000mm，提升式主配+顶升式附加配重，拆装便捷，可带31吨配重随车转场。

下车/Chassis

	驾驶室	▪ 三一自主开发，外开式车门，配置冷暖空调以及卧铺。
	车架	▪ 三一自制结构件，采用高强度钢制造，刚度高、承载能力强。
	车桥	▪ 汉德车桥，轴内置轴间和轮间差速；冲焊桥壳工艺，承载能力更强。
	发动机	▪ 潍柴柴油发动机，排放符合国VI标准；燃油箱有效容积450L。
	传动系统	▪ 12档法士特变速箱，配置同步器。
	制动系统	▪ 行车制动采用双回路制动系统，所有车轮均用空气伺服制动器，前桥采用楔式制动器+双气室； ▪ 驻车制动采用气室内弹簧作用在第二、三、四桥上； ▪ 辅助制动采用发动机制动，保证在下长坡时的制动安全。
	悬挂系统	▪ 多轴平衡板簧悬架。
	转向系统	▪ 1轴+2轴液压助力机械转向，4轴+5轴电液辅助转向。
	驱动	▪ 3轴+4轴+5轴驱动。
	支腿	▪ H型支腿4点支撑，采用细晶粒高强度钢板材料；一、二级支腿全液压横向伸缩，支腿垂直油缸采用双向液压锁进行安全保护。
	轮胎	▪ 全445/95R25。

05 配重组合图

Counterweight Combinations

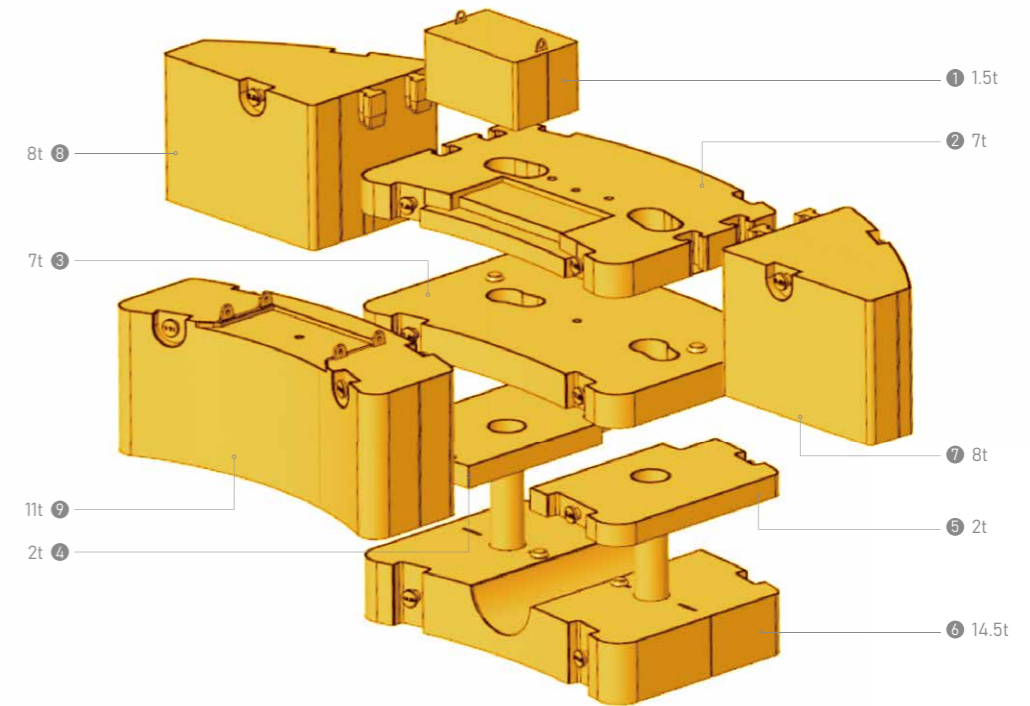

序号	名称	重量 (t)
1	固定配重 (卷扬箱)	1.5
2	活动配重 1	7
3	活动配重 2	7
4	活动配重 3-1	2
5	活动配重 3-2	2
6	活动配重 4	14.5
7	附加配重 1	8
8	附加配重 2	8
9	附加配重 3	11

带行驶配重状态

高速长途：可携带27t配重（前14.5t，后1.5t+11t）和四块支腿垫板、副臂、吊钩、备胎转场
 高速短途：可携带31t配重（前14.5t+2t×2，后1.5t+11t）和四块支腿垫板、副臂、吊钩、备胎转场

06 重载转场图

On-Site Heavy-Duty Driving Solutions

■ 公告状态

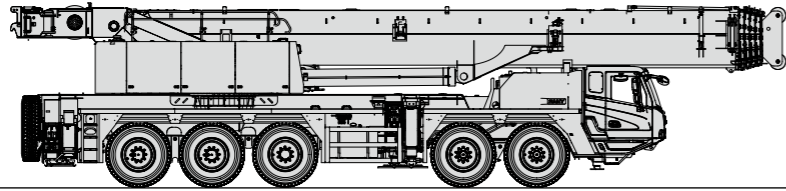

■ 重载转场

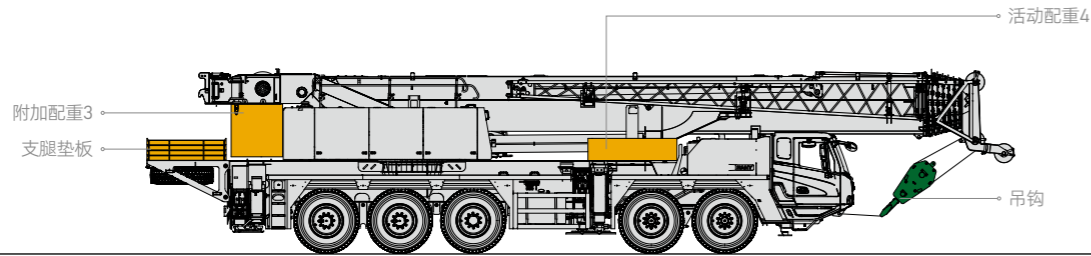

27t

■ 重载转场

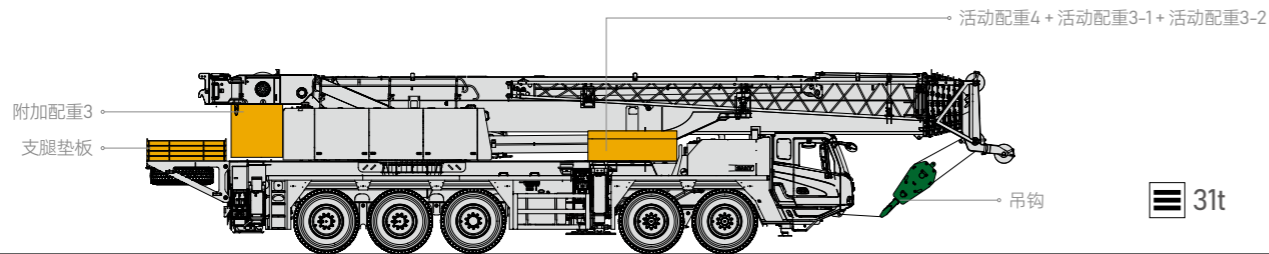

31t

07 起升高度曲线图

主臂 (T)

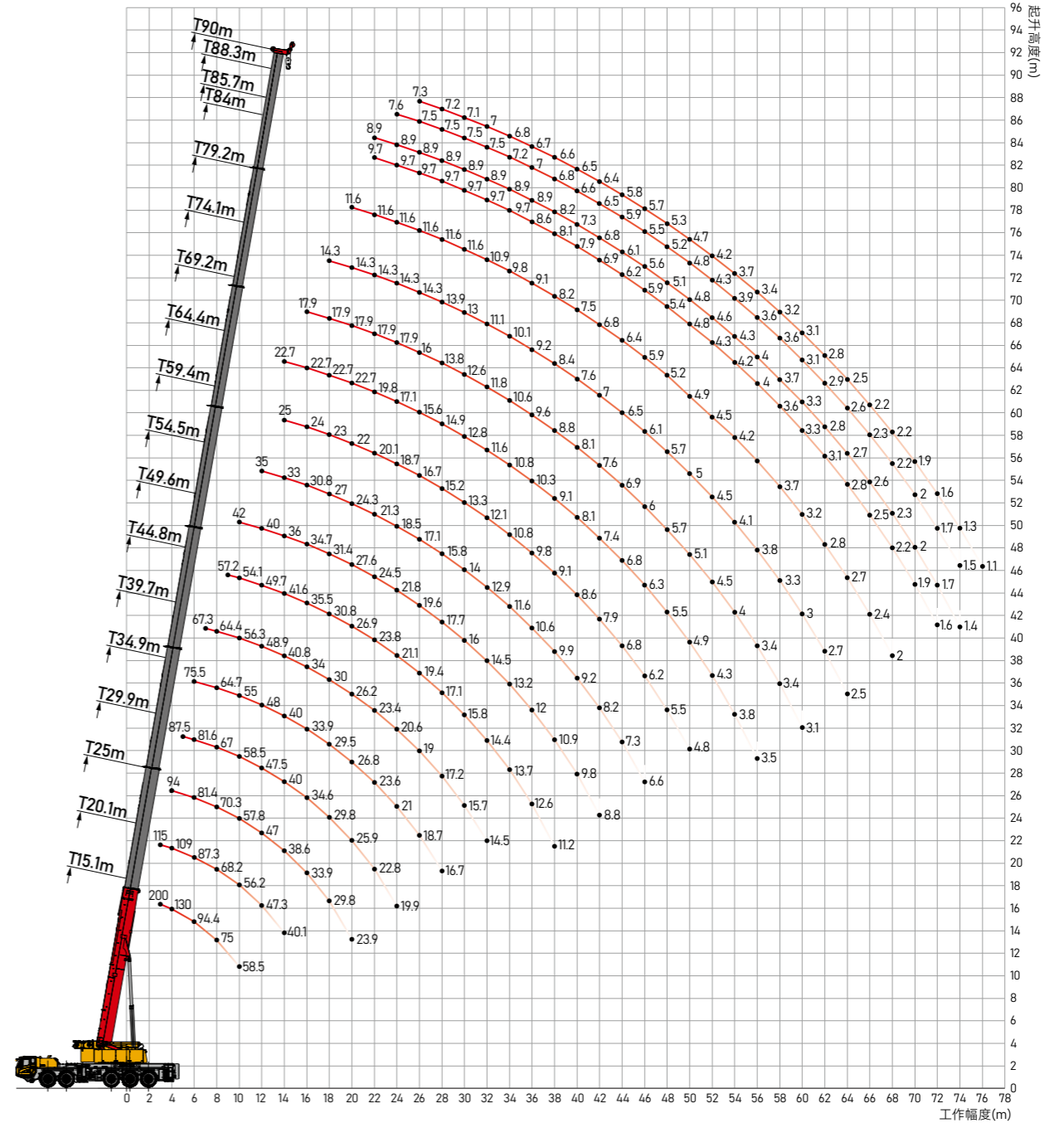
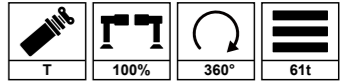

07 起重性能表

主臂 (T)

单位:t

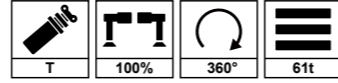

	15.1	20.1	21.0	29.9	34.9	39.8	44.8	49.6	54.5	59.4	59.4	69.2	74.1	79.2	84.0	85.7	88.3	90.0		
3.0	200.0	115.0																	3.0	
3.5	150.0	112.0	99.7																3.5	
4.0	130.0	109.0	94.0																4.0	
4.5	114.5	107.4	92.7	90.0															4.5	
5.0	107.0	98.6	90.5	87.5															5.0	
5.5	100.4	93.6	85.7	84.6															5.5	
6.0	94.4	87.3	81.4	81.6	75.5														6.0	
7.0	84.0	76.1	74.4	74.9	70.8	67.3													7.0	
8.0	75.0	68.2	70.3	67.0	64.7	64.4													8.0	
9.0	66.0	63.2	65.0	63.6	60.4	60.8	57.2												9.0	
10.0	58.5	56.2	57.8	58.5	55.0	56.3	54.1	42.0											10.0	
12.0		47.3	47.0	47.5	48.0	48.9	49.7	40.0	35.0										12.0	
14.0		40.1	38.6	40.0	40.0	40.8	41.6	36.0	33.0	25.0	22.7								14.0	
16.0			33.9	34.6	33.9	34.8	35.5	34.7	30.8	24.0	22.7	17.9							16.0	
18.0			29.8	29.8	29.5	30.0	30.8	31.4	27.0	23.0	22.7	17.9	14.3						18.0	
20.0			23.9	25.9	26.8	26.2	26.9	27.6	24.3	22.0	22.7	17.9	14.3	11.6					20.0	
22.0				22.8	23.6	23.4	23.8	24.5	21.3	20.1	19.8	17.9	14.3	11.6	9.7	8.9			22.0	
24.0				19.9	21.0	20.6	21.1	21.8	18.5	18.7	17.1	17.9	14.3	11.6	9.7	8.9	7.6		24.0	
26.0					18.7	19.0	19.4	19.6	17.1	16.7	15.6	16.0	14.3	11.6	9.7	8.9	7.5	7.3	26.0	
28.0					16.7	17.2	17.1	17.7	15.8	15.2	14.9	13.8	13.9	11.6	9.7	8.9	7.5	7.2	28.0	
30.0						15.7	15.8	16.0	14.0	13.3	12.8	12.6	13.0	11.6	9.7	8.9	7.5	7.1	30.0	
32.0							14.5	14.4	14.5	12.9	12.1	11.6	11.8	11.1	10.9	9.7	8.9	7.5	7.0	32.0
34.0								13.7	13.2	11.6	10.8	10.8	10.6	10.1	9.8	9.7	8.9	7.2	6.8	34.0
36.0								12.6	12.0	10.6	9.8	10.3	9.6	9.2	9.1	8.6	8.9	7.0	6.7	36.0
38.0								11.2	10.9	9.9	9.1	9.1	8.8	8.4	8.2	8.1	8.2	6.8	6.6	38.0
40.0									9.8	9.2	8.6	8.1	8.1	7.6	7.5	7.9	7.3	6.6	6.5	40.0
42.0									8.8	8.2	7.9	7.4	7.6	7.0	6.8	6.9	6.8	6.5	6.4	42.0
44.0										7.3	6.8	6.8	6.9	6.5	6.4	6.2	6.1	5.9	5.8	44.0
46.0										6.6	6.2	6.3	6.0	6.1	5.9	5.9	5.6	5.5	5.7	46.0
48.0											5.5	5.5	5.7	5.7	5.2	5.4	5.1	5.2	5.3	48.0
50.0											4.8	4.9	5.1	5.0	4.9	4.8	4.8	4.8	4.7	50.0
52.0												4.3	4.5	4.5	4.5	4.3	4.6	4.3	4.2	52.0
54.0													3.8	4.0	4.1	4.2	4.3	3.9	3.7	54.0
56.0														3.5	3.4	3.8	3.9	4.0	3.6	56.0
58.0															3.4	3.3	3.7	3.6	3.7	58.0
60.0															3.1	3.0	3.2	3.3	3.1	60.0
62.0																2.7	2.8	3.1	2.8	62.0
64.0																2.5	2.7	2.8	2.7	64.0
66.0																	2.4	2.5	2.6	66.0
68.0																		2.0	2.2	68.0
70.0																			1.9	70.0
72.0																				72.0
74.0																				74.0
76.0																				76.0

07 起重性能表

主臂 (T)

单位:t

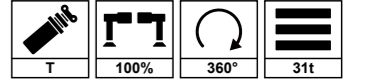

	15.1	20.1	21.0	29.9	34.9	39.8	44.8	49.6	54.5	59.4	59.4	69.2	74.1	79.2	84.0	85.7	88.3	90.0		
3.0	144.0	115.0																		3.0
3.5	132.6	112.0	99.7																	3.5
4.0	122.8	109.0	94.0																	4.0
4.5	112.5	107.4	92.7	90.0																4.5
5.0	101.1	98.6	90.5	87.5																5.0
5.5	91.7	91.6	85.7	84.6																5.5
6.0	83.7	83.6	81.4	81.6	75.5															6.0
7.0	71.0	70.9	69.8	70.4	70.8	67.3														7.0
8.0	61.2	61.8	60.1	60.7	61.5	62.4														8.0
9.0	53.6	54.8	53.3	54.8	55.6	54.7	55.5													9.0
10.0	47.4	48.6	47.9	48.6	49.4	50.1	49.3	42.0												10.0
12.0		39.2	38.5	39.2	40.0	40.8	39.9	40.0	35.0											12.0
14.0		32.4	31.7	32.4	33.2	34.0	34.8	33.9	33.0	25.0	22.7									14.0
16.0			26.9	26.5	27.6	28.7	29.7	28.6	27.6	24.0	22.7	17.9								16.0
18.0			21.6	22.7	22.3	23.4	24.4	23.2	22.3	22.0	22.1	17.9	14.3							18.0
20.0			17.6	18.8	19.4	19.4	20.3	19.2	18.9	18.9	18.6	17.9	14.3	11.6						20.0
22.0				15.7	16.8	16.4	17.2	16.1	16.0	15.8	16.0	16.3	14.3	11.6	9.7	8.9				22.0
24.0					13.2	14.3	15.0	14.7	13.6	13.8	13.3	13.5	13.8	13.2	11.6	9.7	8.9	7.5		24.0
26.0						12.2	13.2	12.6	11.6	11.8	12.1	11.6	11.8	12.2	11.6	9.7	8.9	7.5	7.0	26.0
28.0							11.3	11.5	10.9	10.3	10.1	10.5	10.6	10.3	11.3	10.7	9.7	8.9	7.5	28.0
30.0								10.0	9.5	9.3	8.7	9.0	9.3	9.4	9.9	9.5	8.9	8.9	7.5	30.0
32.0									8.8	8.2	8.4	7.4	7.8	8.3	8.5	8.6	8.3	7.7	7.8	32.0
34.0										7.2	7.3	6.4	6.7	7.2	7.7	7.9	7.2	6.6	6.8	34.0
36.0											6.2	6.4	5.5	5.8	6.3	6.9	7.0	6.3	5.7	36.0
38.0											5.4	5.6	4.6	5.0	5.4	6.1	6.1	5.5	4.9	38.0
40.0												4.8	3.9	4.3	4.7	5.4	5.4	4.7	4.2	40.0
42.0													4.2	3.3	3.8	4.0	4.9	4.8	4.1	42.0
44.0														2.9	3.5	3.5	4.5	4.2	3.5	44.0
46.0															2.5	3.0	2.9	4.0	3.6	46.0
48.0																2.8	2.8	3.5	3.1	48.0
50.0																2.7	2.6	3.1	2.7	50.0
52.0																	2.3	2.7	2.3	52.0
54.0																		2.1	2.3	54.0
56.0																			1.8	56.0
58.0																				58.0
60.0																				60.0

07 起升高度曲线图

主臂+副臂 (TJ)

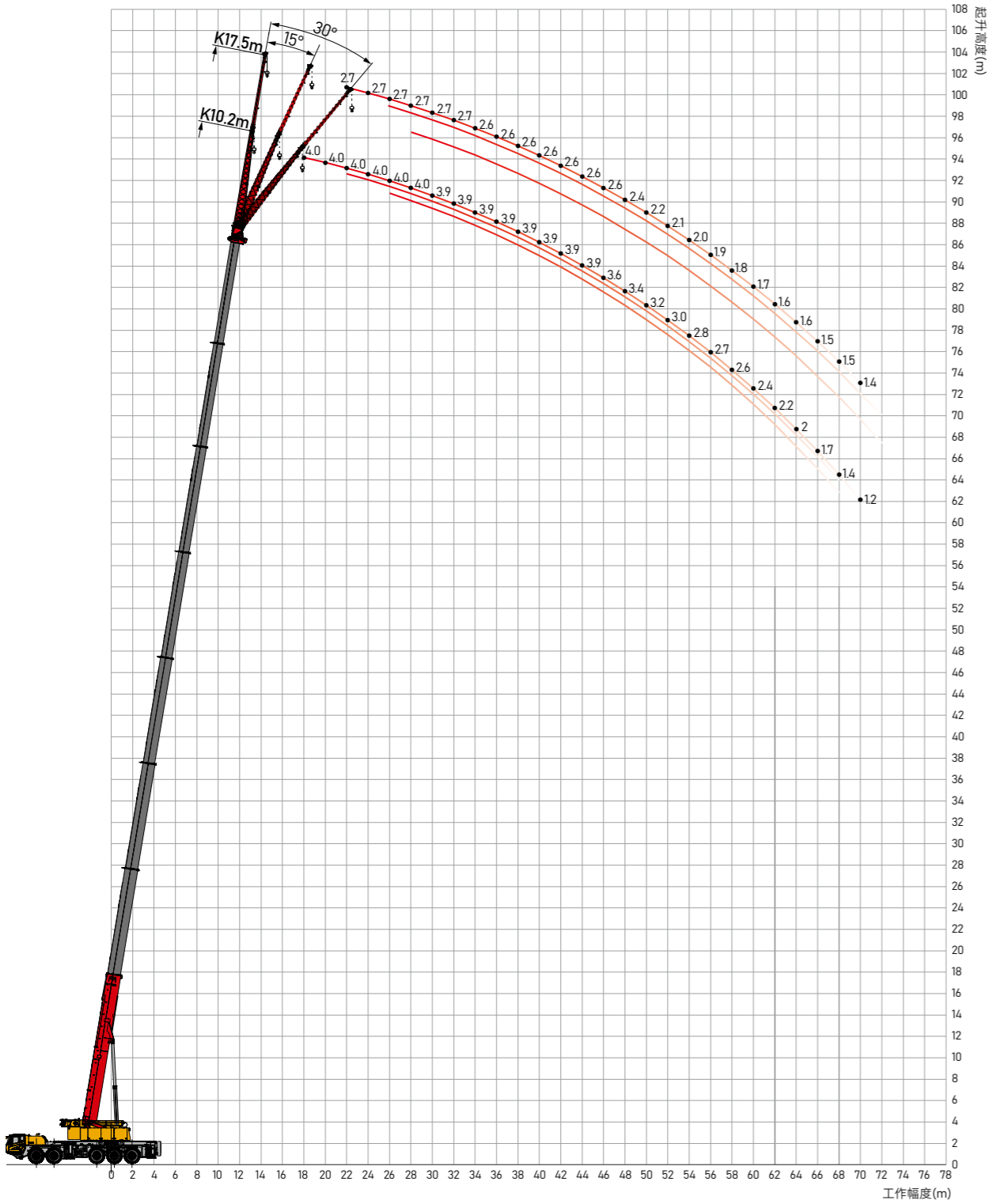
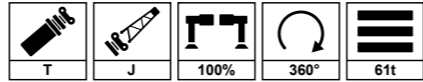

07 起重性能表

主臂+副臂 (TJ)

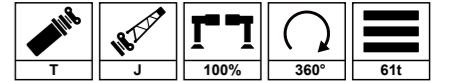

单位: t

起升高度 (m)	84.0+9.0			84.0+10.2			84.0+17.5			84.0+19.7		84.0+27.0		84.0+36.5	
	0	0	15	30	0	15	30	0	0	15	0	0			
18.0		4.0											18.0		
20.0	5.5	4.0											20.0		
22.0	5.4	4.0	3.8		2.7								22.0		
24.0	5.3	4.0	3.8		2.7			2.6	1.9			1.4	24.0		
26.0	5.3	4.0	3.8	3.6	2.7	2.6		2.6	1.9			1.4	26.0		
28.0	5.2	4.0	3.8	3.5	2.7	2.6	2.5	2.5	1.9			1.4	28.0		
30.0	5.0	3.9	3.7	3.5	2.7	2.6	2.5	2.5	1.9	1.8		1.4	30.0		
32.0	4.8	3.9	3.7	3.3	2.7	2.5	2.4	2.5	1.9	1.8		1.4	32.0		
34.0	4.6	3.9	3.7	3.3	2.6	2.5	2.4	2.5	1.9	1.8		1.4	34.0		
36.0	4.4	3.9	3.7	3.3	2.6	2.5	2.3	2.5	1.9	1.8		1.4	36.0		
38.0	4.2	3.9	3.7	3.3	2.6	2.5	2.3	2.4	1.9	1.8		1.4	38.0		
40.0	4.0	3.9	3.7	3.3	2.6	2.4	2.2	2.4	1.9	1.8		1.4	40.0		
42.0	3.9	3.9	3.4	3.3	2.6	2.4	2.2	2.4	1.9	1.8		1.4	42.0		
44.0	3.6	3.9	3.2	3.2	2.6	2.3	2.2	2.4	1.9	1.7		1.4	44.0		
46.0	3.4	3.6	3.0	3.2	2.6	2.2	2.2	2.4	1.9	1.7		1.4	46.0		
48.0	3.2	3.4	2.8	3.0	2.4	2.0	2.1	2.3	1.9	1.7		1.4	48.0		
50.0	3.0	3.2	2.6	2.9	2.2	2.0	2.1	2.2	1.9	1.7		1.4	50.0		
52.0	2.8	3.0	2.4	2.9	2.1	2.0	2.1	2.1	1.9	1.7		1.4	52.0		
54.0	2.5	2.8	2.3	2.8	2.0	1.9	2.1	2.0	1.9	1.7		1.3	54.0		
56.0	2.2	2.7	2.2	2.7	1.9	1.9	2.0	1.9	1.9	1.7		1.3	56.0		
58.0	1.9	2.6	2.1	2.6	1.8	1.9	2.0	1.7	1.9	1.6		1.3	58.0		
60.0	1.7	2.4	2.0	2.6	1.7	1.9	1.9	1.5	1.9	1.6		1.3	60.0		
62.0	1.4	2.2	1.9	2.4	1.6	1.8	1.9	1.3	1.8	1.5		1.3	62.0		
64.0	1.2	2.0	1.9	2.3	1.6	1.8	1.8	1.0	1.7	1.5			64.0		
66.0	1.0	1.7	1.8	2.0	1.5	1.8	1.8		1.6	1.5			66.0		
68.0		1.4	1.8	1.7	1.5	1.7	1.8		1.4	1.5			68.0		
70.0		1.2			1.4	1.5	1.8			1.4			70.0		
72.0						1.3	1.6						72.0		

07 起升高度曲线图

主臂+延伸臂 (TE)

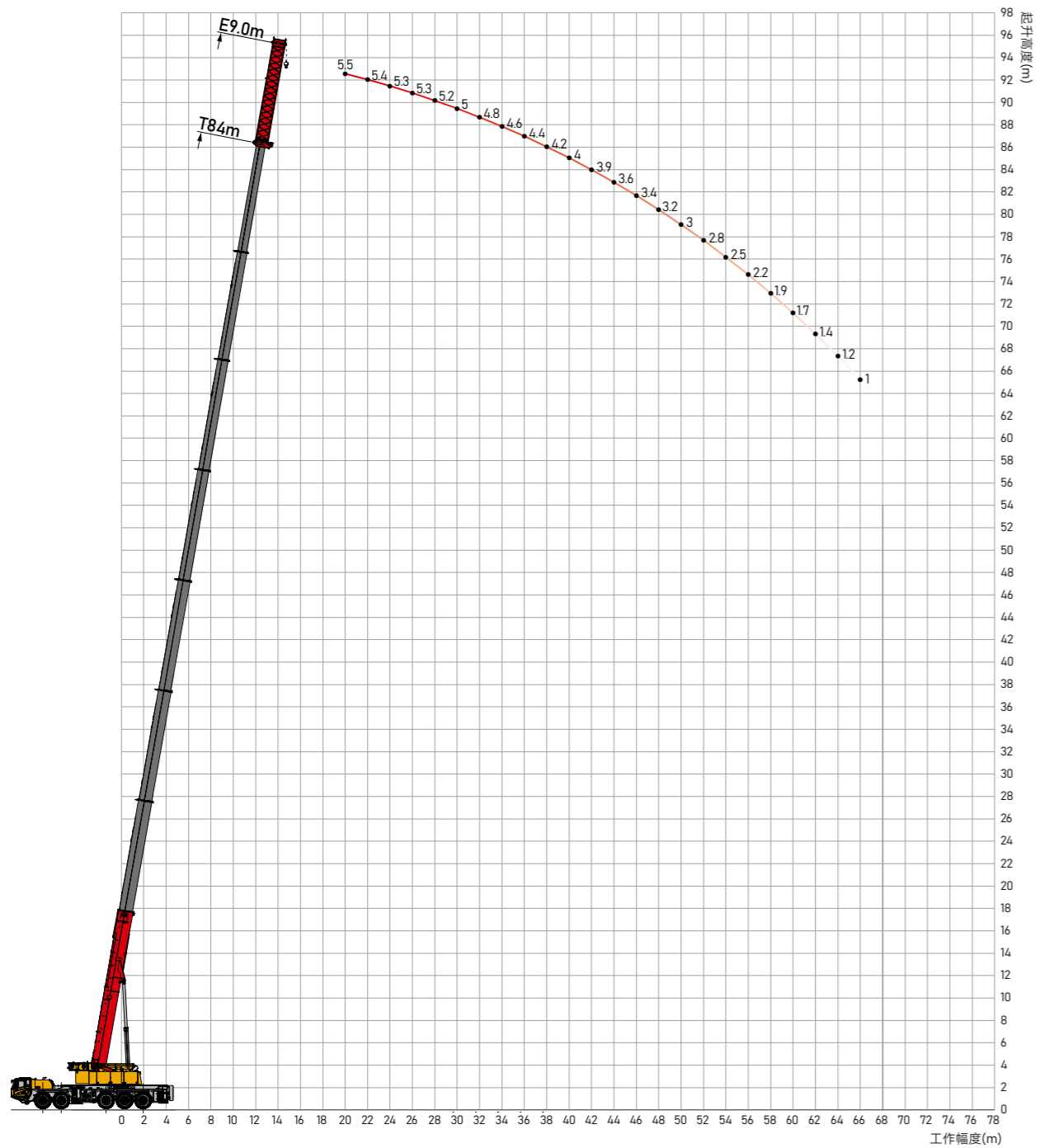
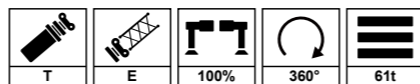

07 起升高度曲线图

主臂+延伸臂+副臂 (TEJ)

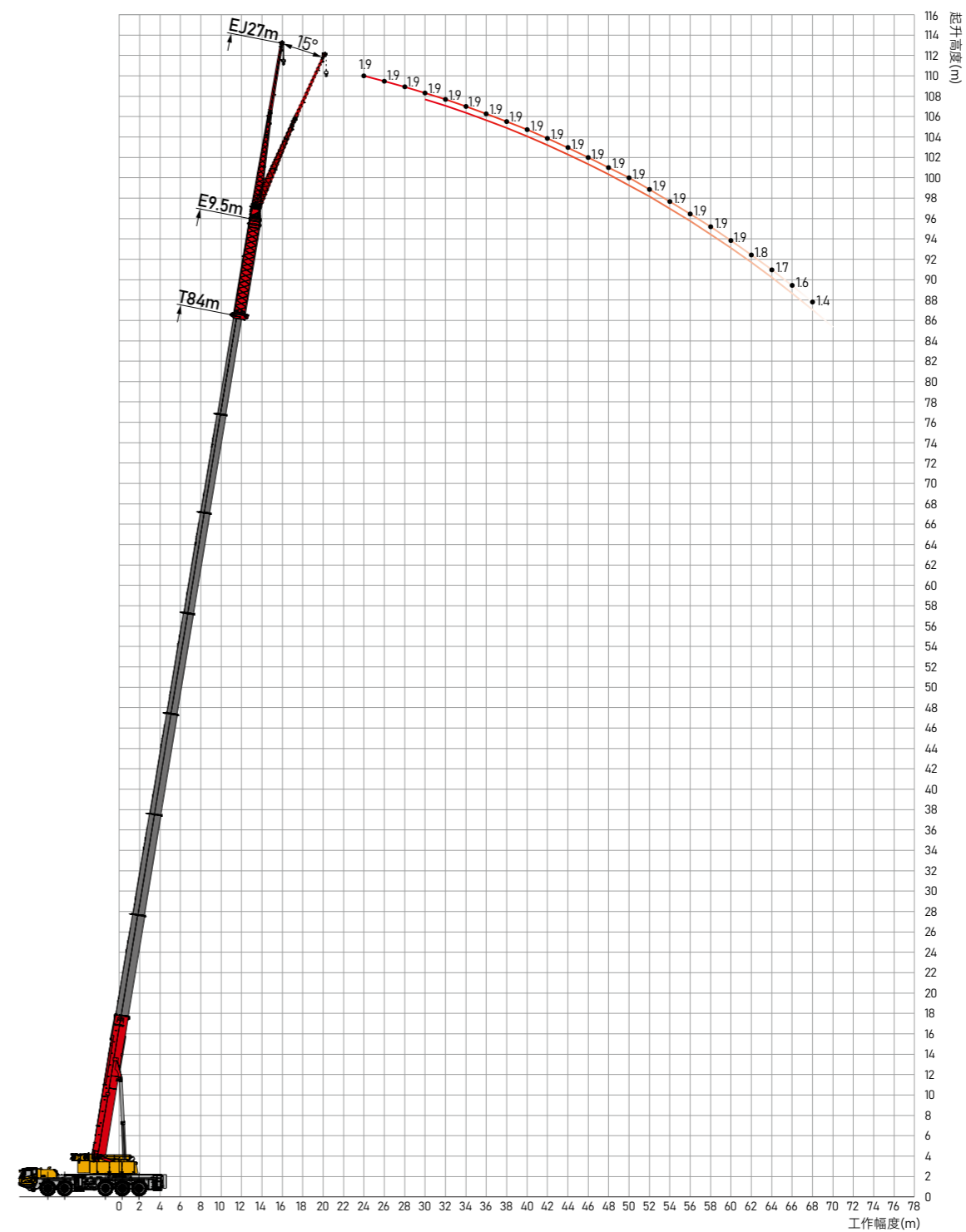
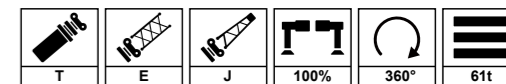

07 起升高度曲线图

主臂+延伸臂+副臂 (TEJ)

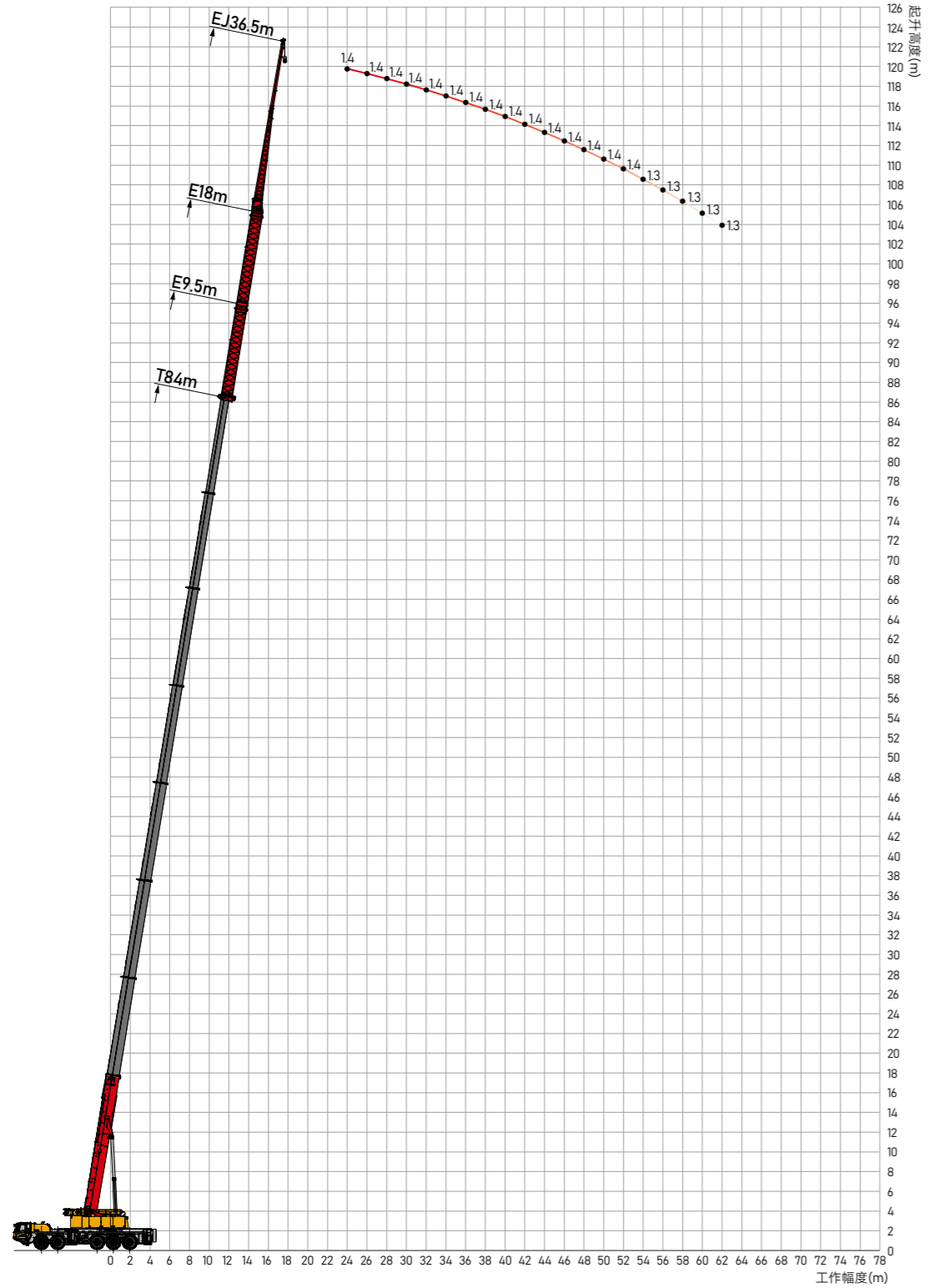
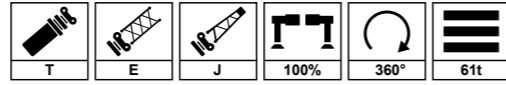



三一汽车起重机械有限公司

中国湖南长沙金洲开发区金洲大道168号 邮编：410600

电话：0731-8787 3131 传真：0731-8403 1999-196 邮箱：qzjyx@sany.com.cn

售后服务热线：400 887 8318 咨询投诉电话：400 887 9318

温馨提示：

为了使您的柴油机安全可靠的运行，国VI机型请添加符合国家标准国VI柴油及尿素溶液，具体参见使用说明书及相关标准。

由于技术不断更新，技术参数及配置如有更改，恕不另行通知。图片上的机器可能包括附加设备，本画册仅供参考，以实物为准。

版权为三一重工所有，未经三一重工书面许可，本目录任何部分的内容不得被复制或抄袭用于任何目的。

©中国印刷 2024 年 1 月版

www.sanygroup.com



扫描二维码
关注三一汽车起重机公众号